

MODEL LD22i

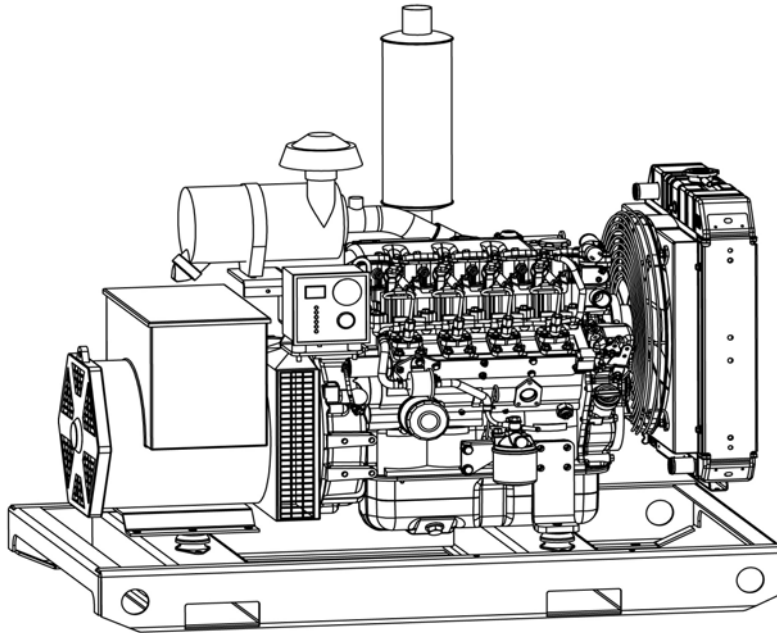

Ratings

Voltage:	120/240	120/240	416/208/240	440/220/254	460/230/266	480/240/277
Leads:	4 Wire	12 Wire	12 Wire	12 Wire	12 Wire	12 Wire
Rated PF:	1.0	1.0	0.8	0.8	0.8	0.8
Standby kW:	21.3	20.8	21.4	21.4	21.5	21.5
Prime kW:	19.1	18.7	19.2	19.3	19.3	19.4

Standard Features

GenSet

Direct drive 1800 rpm mounted on a rugged formed steel base. Forklift channels. Antivibration mounts with protective cap and captive design. Keyswitch control panel with first fault indication and safety shutdowns for high water temperature and low oil pressure. Electric fuel transfer pump. Battery rack and cables

Engine

Isuzu liquid cooled diesel engine. EPA Tier 4i. Glow plug starting aid. 5% mechanical speed governing no load - full load. Engine mounted copper core radiator with pusher fan and finger guard. One sided maintenance engine design.

Generator

Newage Stamford single bearing alternator. Automatic voltage regulation (SX460). Class H insulation. CSA approved construction.

Specifications

Engine		Alternator	
Model	4LE2	Model	BCI184
Type	Vertical 4-cycle Water Cooled	Insulation	Class H
No. of Cylinders	4	Protection	IP23
Displacement	2.2L	Winding Leads	12
Combustion System	Natural Aspirated	R.F.I. Suppression	BS EN 61000-6-2 & BS EN 61000-6-4, VDE 0875G, VDE 0875N.
Compression Ratio	18.8:1	Waveform Distortion	No Load < 1.5% Non-Distorting Balanced Linear Load < 5.0%
Lubricating Oil	Quality better than CD	Max. Overspeed	2250 Rev/Min
Oil Pan Capacity	8.4L	Total Weight Kg (Lb)	151 (332.2)
Oil Change Interval	500 Hr	WR ² Inertia	0.1909 kgm ²
Cooling System	Water Cooled	Telephone Interference	TIF<50
Alternator Capacity	12V 20A	Cooling Air	0.119 m ³ /sec 250 cfm
Fuel	Diesel Fuel		
Dry Weight kg (lb)	173 (380.6)		
Standby Power kWm (Hp)	25.0 (33.5)		
Continuous Power kWm (Hp)	22.3 (29.9)		

Genset

Fuel Consumption

Full Load Standby	L/Hr	7.25
	USGPH	1.92
Full Load Prime	L/Hr	6.06
	USGPH	1.60

Estimated Dry Weight: 415 kg
913 lbs

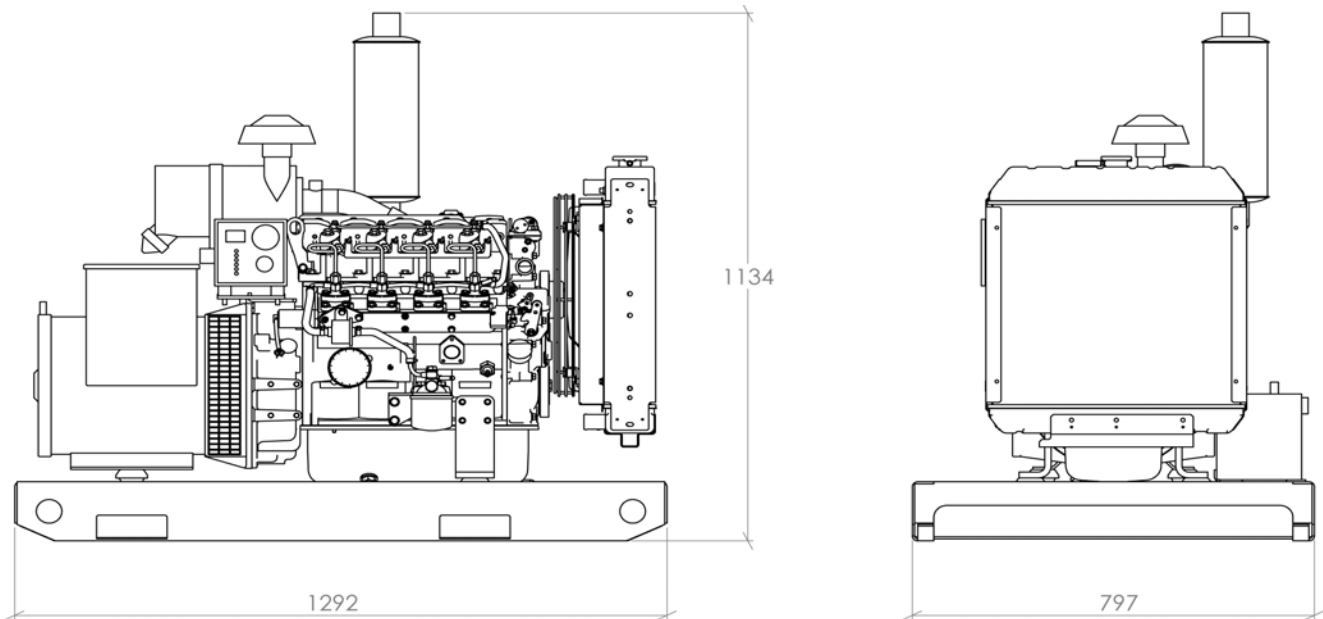

FOR REFERENCE ONLY
NOT FOR INSTALLATION PURPOSES

Optional Equipment

Control Panel

Custom control panels available
AC meter package
AC Ammeter
AC Voltmeter
Frequency meter
Phase Selector switch
Distribution panel

Cooling System

City water cooling
Heat exchanger cooling
Remote radiator

Fuel System

Above ground fuel tank
Auxiliary fuel pump and heaters
Day tank
Fuel/water separators
Sub-base mounted fuel tank
Double wall
Single wall

Exhaust System

Industrial grade muffler (Std)
Residential grade muffler
Critical grade muffler
Hospital grade muffler
Flexible exhaust connector

Lubricating System

Crankcase oil heater
Oil drain extension
Oil level maintainer with lube oil tank
Oil sump heater
Pre-lube pump

Engine Electrical System

Battery cable
Battery charger
Battery box
Battery warmer
12 or 24 Volt

Generator

Main line circuit breaker
anti-condensation heaters

Accessories

Jacket water heater
Remote annunciator
Sound attenuated enclosures
Trailer mounted package
All weather protective housings
Spring vibration isolators
Single point lifting lug
Isochronous governor
Positive air shutoff
Planned maintenance contracts
Long term service agreements

TPG Pritchard Dieseltech

A division of Pritchard Engineering Ltd.
100 Otter St. Winnipeg, MB
Ph: 1-204-452-4334
Toll Free: 1-800-665-7665
