

MODEL AD30

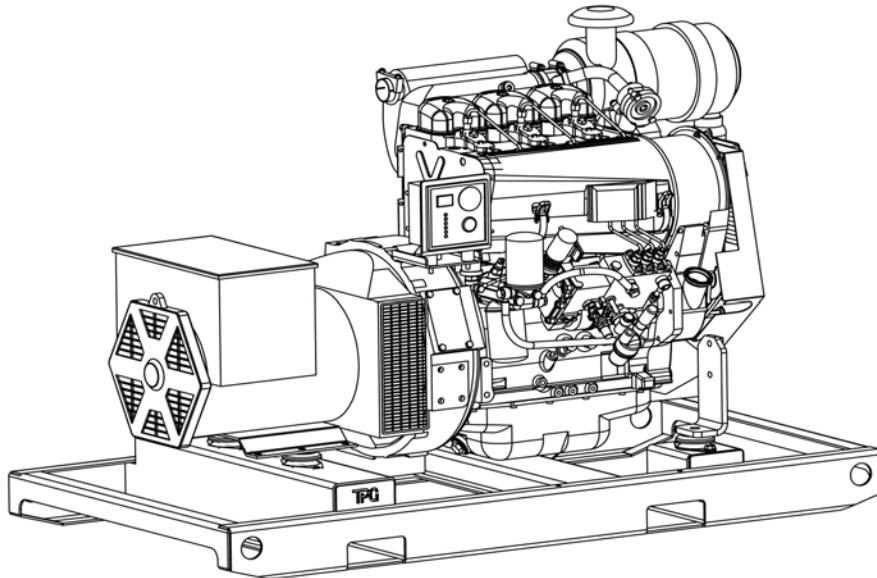

Ratings

Voltage:	120/240	120/240*	416/208/240*	440/220/254	460/230/266	480/240/277
Leads:	4 Wire	12 Wire	12 Wire	12 Wire	12 Wire	12 Wire
Rated PF:	1.0	1.0	0.8	0.8	0.8	0.8
Standby kW:	29.7	28.9	29.7	29.8	29.9	30.0
Prime kW:	27.0	26.2	27.1	27.1	27.2	27.3

*Optional alternator required for rating shown

Standard Features

GenSet

Direct drive 1800 rpm mounted on a rugged formed steel base. Forklift channels. Antivibration mounts with protective cap and captive design. Keyswitch control panel with first fault indication and safety shutdowns for high water temperature and low oil pressure. Battery rack and cables

Engine

Deutz integrated air/oil cooled diesel engine. EPA Tier 3 Certified. Displacement: 1.078 l /cylinder. Acoustically optimized crankcase. All service points on the same engine side. Compact design and low weight. Worldwide service network with over 1,000 locations.

Generator

Newage Stamford single bearing alternator. Automatic voltage regulation (SX460). Class H insulation. CSA approved construction.

Specifications

Engine		Alternator	
Model	D914L03	Model	BCI184
Type	Vertical 4-cycle Air Cooled	Insulation	Class H
		Protection	IP23
No. of Cylinders	3	Winding Leads	12
Displacement	3.234	R.F.I. Suppression	BS EN 61000-6-2 & BS EN 61000-6-4, VDE 0875G, VDE 0875N.
Combustion System	Natural Aspirated	Waveform Distortion	No Load < 1.5% Non-Distorting Balanced Linear Load < 5.0%
Compression Ratio	19:1	Max. Overspeed	2250 Rev/Min
Lubricating Oil	Quality better than CD	Total Weight Kg (Lb)	167 (367.4)
Oil Change Interval	500 Hrs	WR ² Inertia	0.22 kgm ²
Cooling System	Integrated Air Cooling	Telephone Interference	TIF<50
Alternator Capacity	14V 55A	Cooling Air	0.119 m ³ /sec 250 cfm
Fuel	Diesel Fuel		
Dry Weight kg (lb)	277 (609.4)		
Standby Power kWm (Hp)	34.5 (46.2)		
Continuous Power kWm (Hp)	31.2 (41.8)		

Genset

Fuel Consumption

Full Load Standby	L/Hr	9.74
	USGPH	2.58
Full Load Prime	L/Hr	8.81
	USGPH	2.33

Estimated Dry Weight: 535 kg
1177 lbs

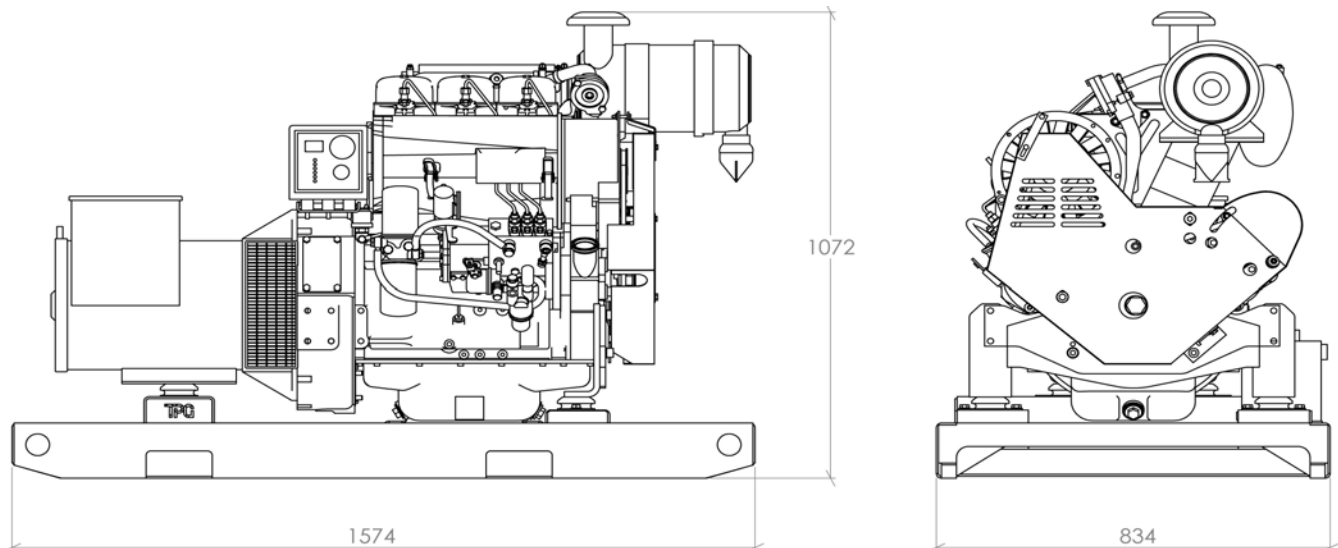

FOR REFERENCE ONLY
NOT FOR INSTALLATION PURPOSES

Optional Equipment

Control Panel

Custom control panels available
AC meter package
AC Ammeter
AC Voltmeter
Frequency meter
Phase Selector switch
Distribution panel

Cooling System

City water cooling
Heat exchanger cooling
Remote radiator

Fuel System

Above ground fuel tank
Auxiliary fuel pump and heaters
Day tank
Fuel/water separators
Sub-base mounted fuel tank
Double wall
Single wall

Exhaust System

Industrial grade muffler (Std)
Residential grade muffler
Critical grade muffler
Hospital grade muffler
Flexible exhaust connector

Lubricating System

Crankcase oil heater
Oil drain extension
Oil level maintainer with lube oil tank
Oil sump heater
Pre-lube pump

Engine Electrical System

Battery cable
Battery charger
Battery box
Battery warmer
12 or 24 Volt

Generator

Main line circuit breaker
anti-condensation heaters

Accessories

Jacket water heater
Remote annunciator
Sound attenuated enclosures
Trailer mounted package
All weather protective housings
Spring vibration isolators
Single point lifting lug
Isochronous governor
Positive air shutoff
Planned maintenance contracts
Long term service agreements

TPG Pritchard Dieseltech

A division of Pritchard Engineering Ltd.
100 Otter St. Winnipeg, MB
Ph: 1-204-452-4334
Toll Free: 1-800-665-7665