

## MODEL AD60

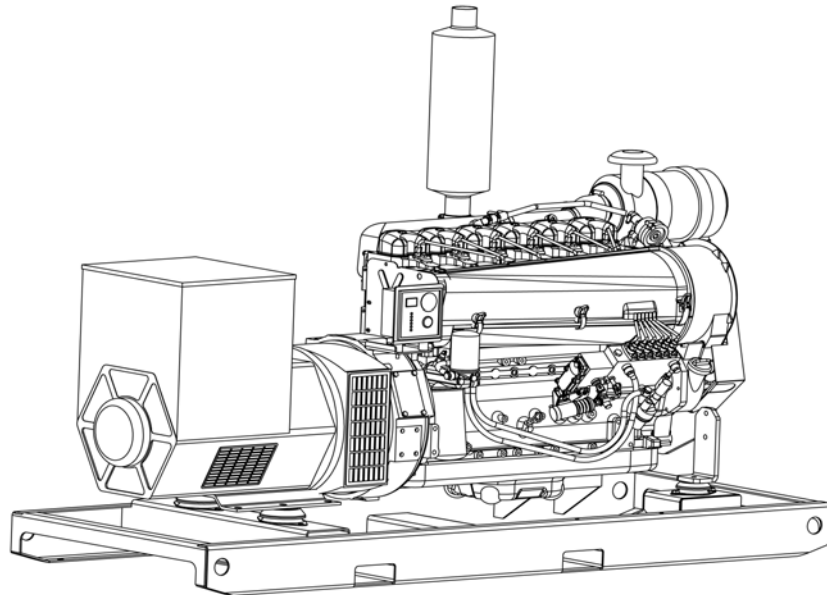

## Ratings

Voltage:	120/240	120/240	416/208/240	440/220/254	460/230/266	480/240/277
Leads:	4 Wire	12 Wire	12 Wire	12 Wire	12 Wire	12 Wire
Rated PF:	1.0	1.0	0.8	0.8	0.8	0.8
Standby kW:	64.3	62.5	65.3	65.6	65.6	65.7
Prime kW:	58.5	57.3	59.4	59.5	59.6	59.7

## Standard Features

### GenSet

Direct drive 1800 rpm mounted on a rugged formed steel base. Forklift channels. Antivibration mounts with protective cap and captive design. Keyswitch control panel with first fault indication and safety shutdowns for high water temperature and low oil pressure. Battery rack and cables

### Engine

Deutz integrated air/oil cooled diesel engine. EPA Tier 3 Certified. Displacement: 1.078 l /cylinder. Acoustically optimized crankcase. All service points on the same engine side. Compact design and low weight. Worldwide service network with over 1,000 locations.

### Generator

Newage Stamford single bearing alternator. Automatic voltage regulation (SX460). Class H insulation. CSA approved construction.

# Specifications

Engine		Alternator	
Model	D914L06	Model	UCI224
Type	Vertical 4-cycle Air Cooled	Insulation Protection	Class H IP23
No. of Cylinders	6	Winding Leads	12
Displacement	6.468	R.F.I. Suppression	BS EN 61000-6-2 & BS EN 61000-6-4, VDE 0875G, VDE 0875N.
Combustion System	Natural Aspirated	Waveform Distortion	No Load < 1.5% Non-Distorting Balanced Linear Load < 5.0%
Compression Ratio	21:1	Max. Overspeed	2250 Rev/Min
Lubricating Oil	Quality better than CD	Total Weight Kg (Lb)	383 (842.6)
Oil Change Interval	500 Hrs	WR <sup>2</sup> Inertia	0.7136 kgm <sup>2</sup>
Cooling System	Integrated Air Cooling	Telephone Interference	TIF<50
Alternator Capacity	14V 55A	Cooling Air	0.281 m <sup>3</sup> /sec 595 cfm
Fuel	Diesel Fuel		
Dry Weight kg (lb)	541 (1190.2)		
Standby Power kWm (Hp)	72.2 (96.7)		
Continuous Power kWm (Hp)	65.4 (87.6)		

## Genset

### Fuel Consumption

Full Load Standby	L/Hr	17.58
	USGPH	4.65
Full Load Prime	L/Hr	15.92
	USGPH	4.21

**Estimated Dry Weight:** 1015 kg  
2233 lbs

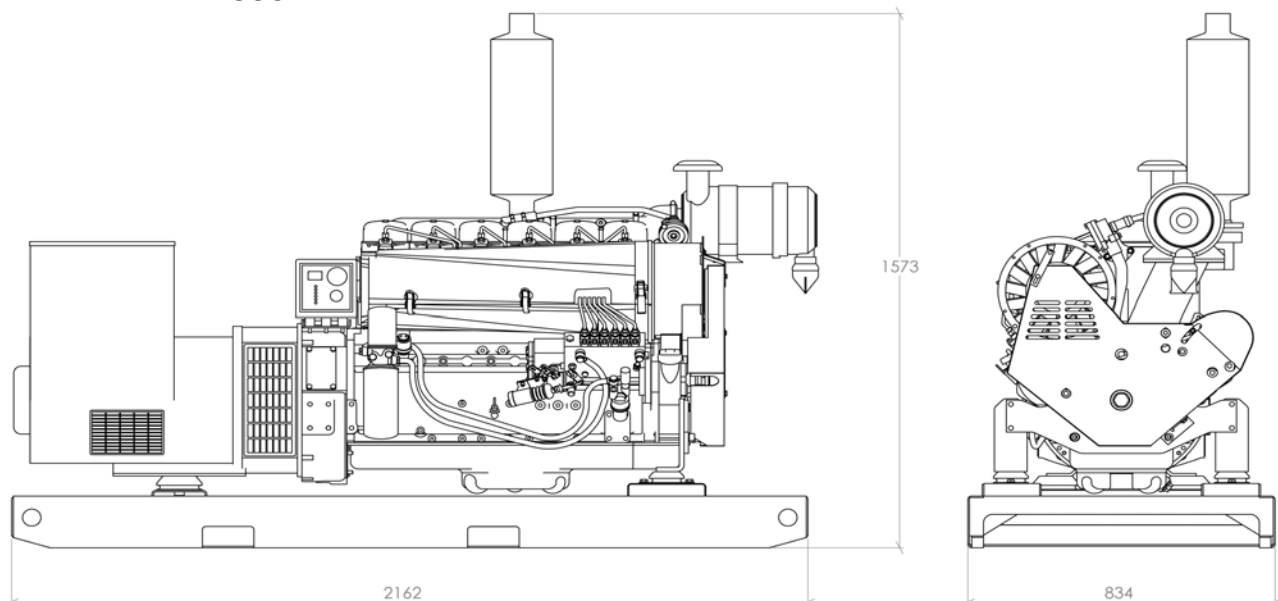

FOR REFERENCE ONLY  
NOT FOR INSTALLATION PURPOSES

---

---

## Optional Equipment

---

---

### Control Panel

Custom control panels available  
AC meter package  
AC Ammeter  
AC Voltmeter  
Frequency meter  
Phase Selector switch  
Distribution panel

### Cooling System

City water cooling  
Heat exchanger cooling  
Remote radiator

### Fuel System

Above ground fuel tank  
Auxiliary fuel pump and heaters  
Day tank  
Fuel/water separators  
Sub-base mounted fuel tank  
Double wall  
Single wall

### Exhaust System

Industrial grade muffler (Std)  
Residential grade muffler  
Critical grade muffler  
Hospital grade muffler  
Flexible exhaust connector

### Lubricating System

Crankcase oil heater  
Oil drain extension  
Oil level maintainer with lube oil tank  
Oil sump heater  
Pre-lube pump

### Engine Electrical System

Battery cable  
Battery charger  
Battery box  
Battery warmer  
12 or 24 Volt

### Generator

Main line circuit breaker  
anti-condensation heaters  
Permenant magnet generator (PMG)

### Accessories

Jacket water heater  
Remote annunciator  
Sound attenuated enclosures  
Trailer mounted package  
All weather protective housings  
Spring vibration isolators  
Single point lifting lug  
Isochronous governor  
Positive air shutoff  
Planned maintenance contracts  
Long term service agreements

**TPG Pritchard Dieseltech**

A division of Pritchard Engineering Ltd.  
100 Otter St. Winnipeg, MB  
Ph: 1-204-452-4334  
Toll Free: 1-800-665-7665

---