

Cab mountings

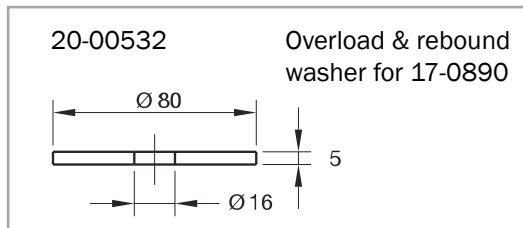

Metalastik® type Cab Mountings

Specially profiled rubber section together with bump and rebound washers provide optimum suspension characteristics for cabs on commercial vehicles, tractors and other off-road vehicles.

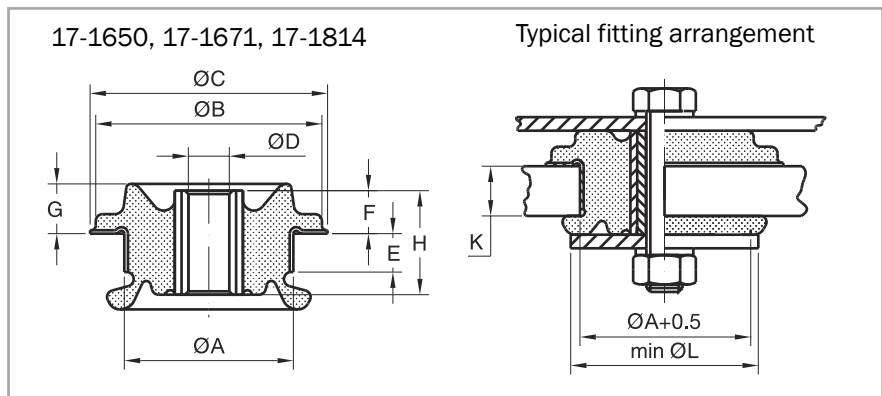
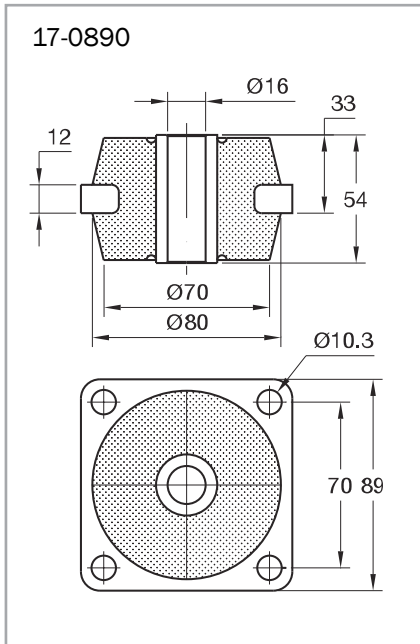
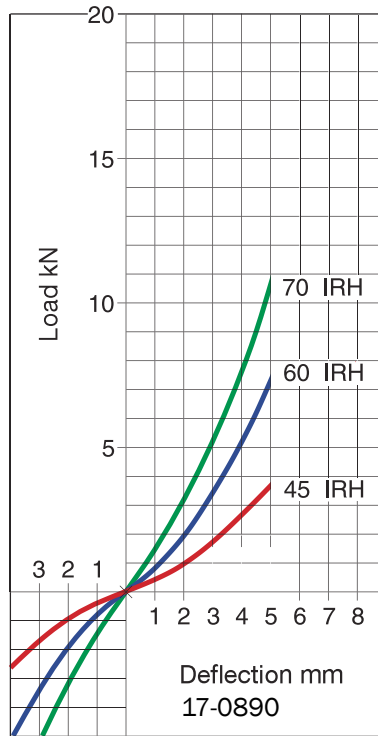

Drawing no.	Part no.	Dimensions in mm										Max load (Kg)	Radial Stiffness (N/mm)	Weight (Kg)
		A	B	C	D	H	F	E	G	K	L			
17-1671-1	10-00563	75	100	105	16,5	46	19	17	22	20	105	160	500	0,45
17-1650-1	10-00554	75	100	105	16,5	46	19	17	22	20	105	300	650	0,46
17-1650-1	10-00555	75	100	105	16,5	46	19	17	22	20	105	500	1300	0,46
17-1814	10-00598	89	115	120	25	47	13	23	21	25	120	410	700	0,63
17-1814	10-00603	89	115	120	25	47	13	23	21	25	120	760	1400	0,63
17-0890	10-00440	see drawings										see table	0,83	
17-0890	10-00441												0,83	
17-0890	10-00442												0,83	
Washer	20-00532												0,83	

Note: The natural frequencies and degrees of isolation are based on dynamic characteristics of the mountings.

Load per mounting (kg)

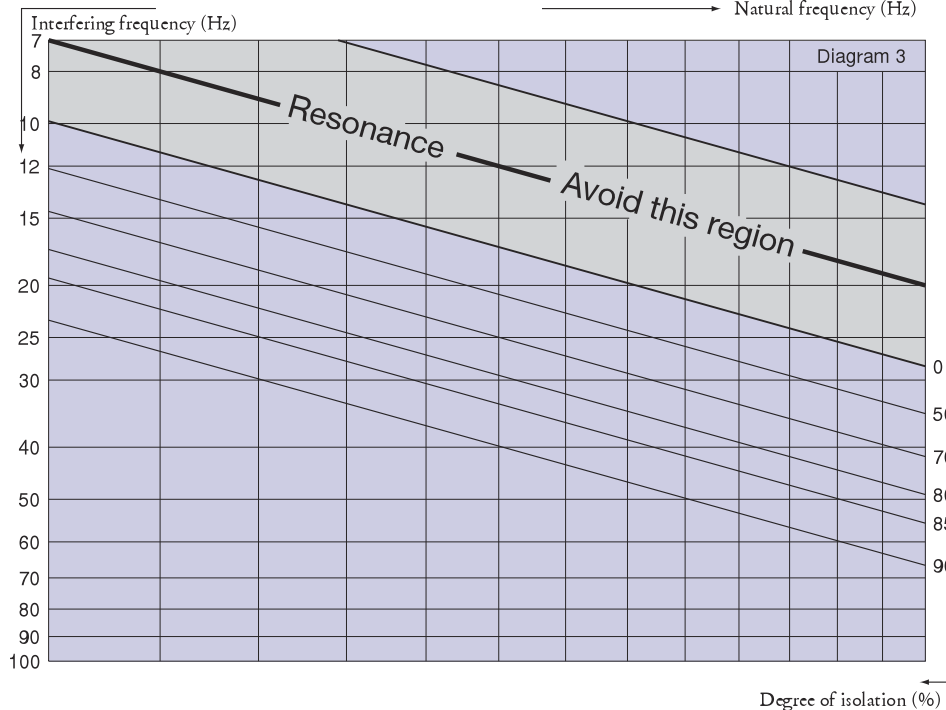
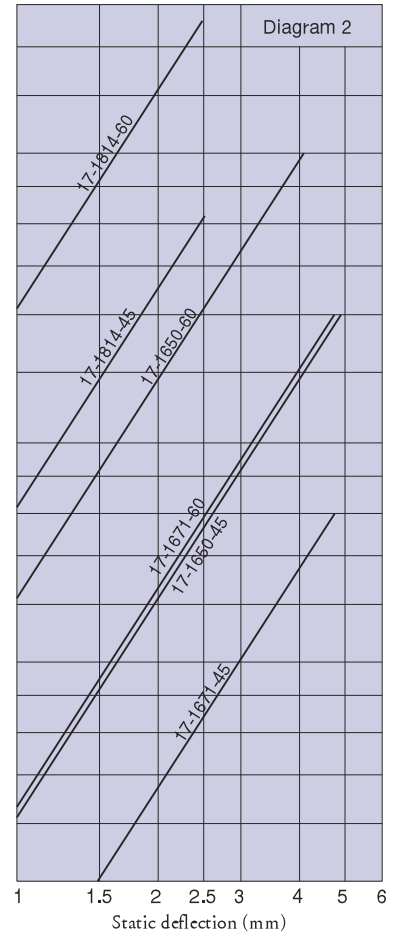
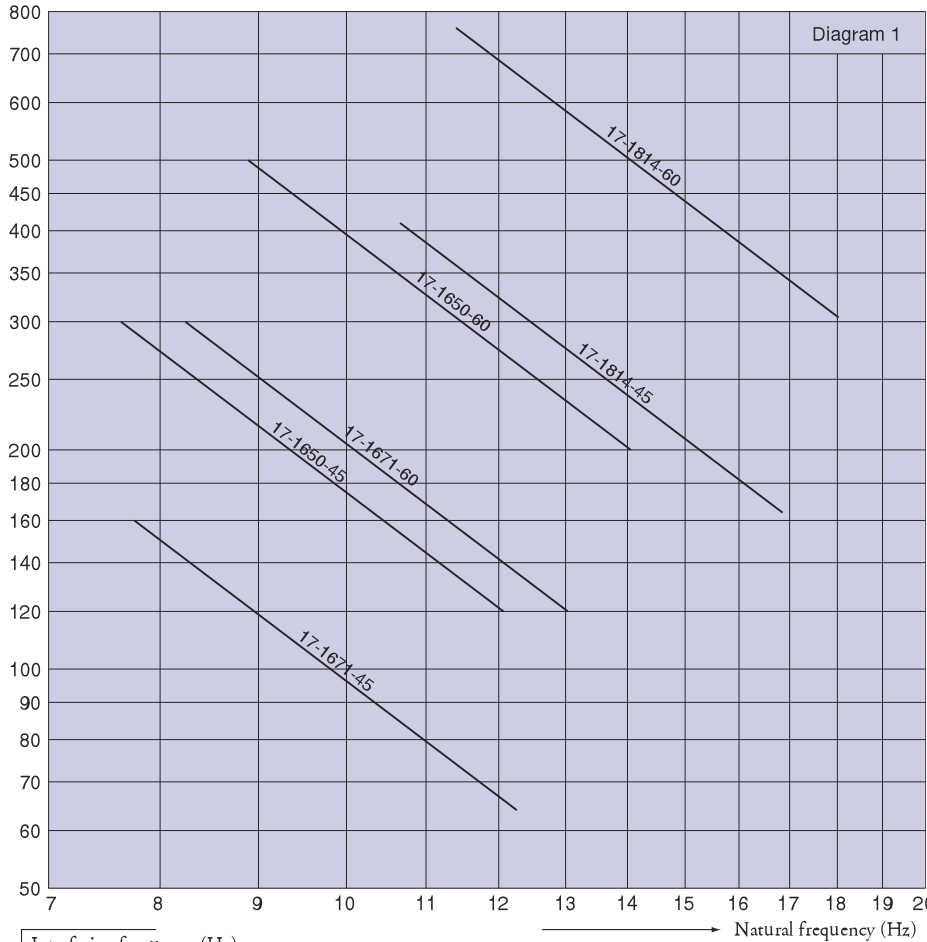

To select correct mounting, following data are needed:
 1) Load per mounting (kg)
 2) Interfering frequency (Hz)
 (Hz = rpm / 60)
 Select correct load line in diagram 1 and correct interference line in diagram 3.
 The load line intersects with required type of mounting.
 Connect this intersection point vertically down to the interference line in diagram 3.
 Here, on the sloping curve, the isolation degree is indicated.
 For static deflection, see diagram 2.

