

Cushyfoot™



Features

Cushyfoot™ mountings have two rubber elements, used in shear and compression, to provide excellent stiffness characteristics for the isolation of a wide range of vibration frequencies.

There are three sizes, 17-0290 for loads up to 230 kg per mounting, 17-0213 for loads up to 1250 kg and 17-0346, which will carry up to 1280 kg per mounting, but will provide up to 16 mm static deflection.

The Cushyfoot™ mounting has the following features:

- ▼ A wide load range from 50 to 1280 kg.
- ▼ Dissimilar horizontal stiffnesses give optimum vibration isolation and motion control.
- ▼ Strong castings for safety and reliability.
- ▼ Stamped identification plates for product identification.

Metalastik® type Cushyfoot™

Cushyfoot™ mountings are suitable for many different types of machinery, e.g. diesel engines, generator sets, compressors, fans, hydraulic units and lift machinery.

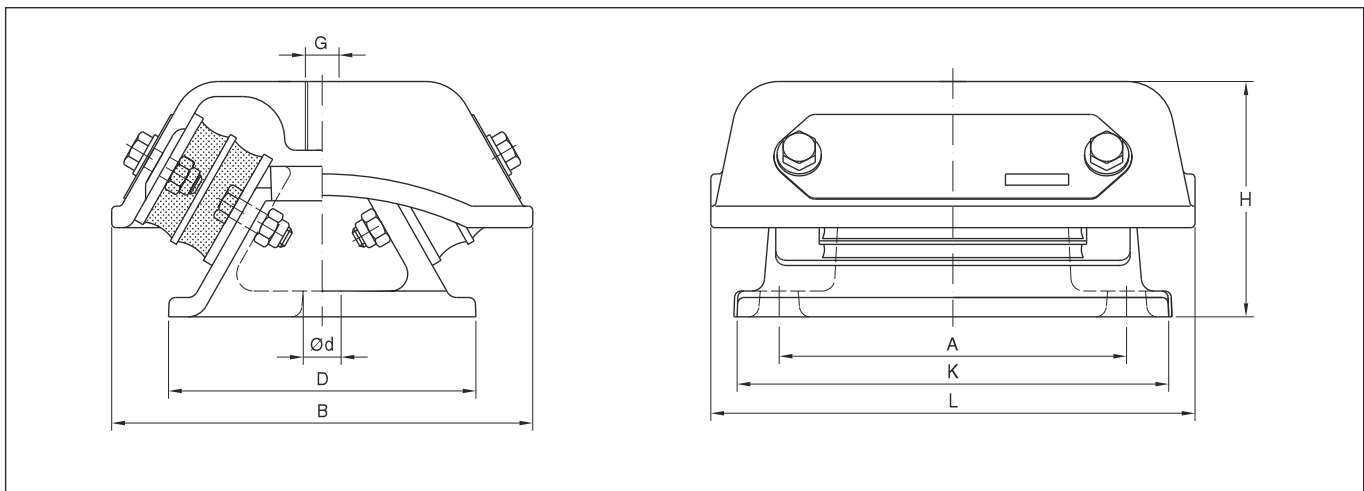

Drawing no.	Part no.				Dimensions in mm								Weight (Kg)	M Max (Kg)			
	45°IRH	55°IRH	60°IRH	70°IRH	L	B	A	K	H	D	d	G		45°IRH	55°IRH	60°IRH	70°IRH
17-0290	20-00689	-	10-04251	-	122	132	90	114	72	82	13	M16	2,3	120	-	230	-
17-0213	10-04106	-	10-04104	10-04103	230	204	165	205	110	148	18	M16	10	590	-	1250	1650
17-0346	10-04234	-	10-04120	-	230	204	165	205	123	148	18	M16	9,5	630	990	1280	-

Note: The natural frequencies and degrees of isolation are based on dynamic characteristics of the mountings.

Load per mounting (kg)

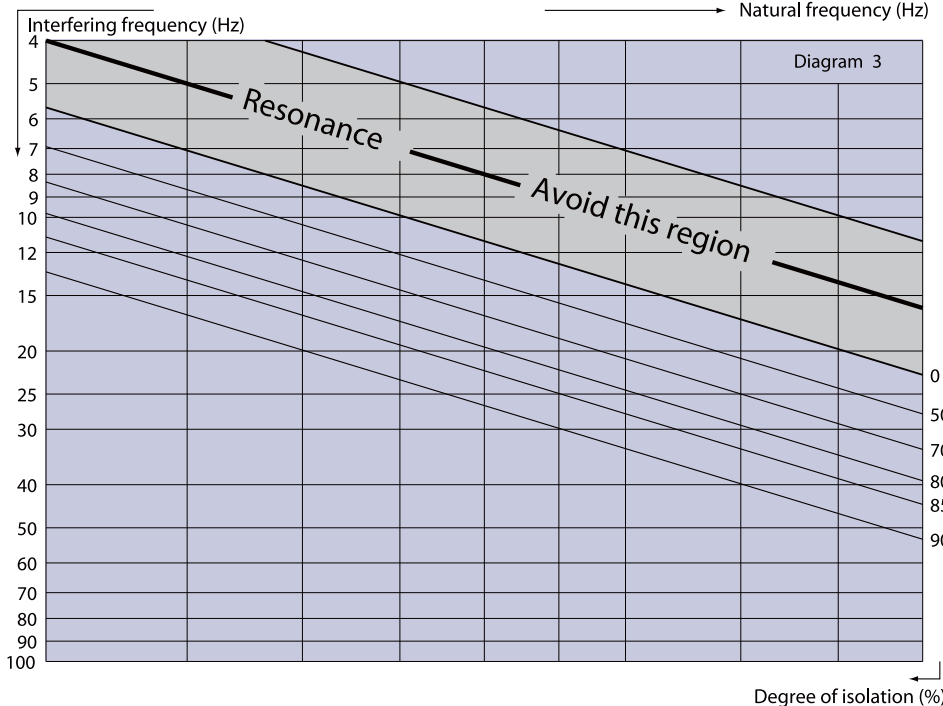
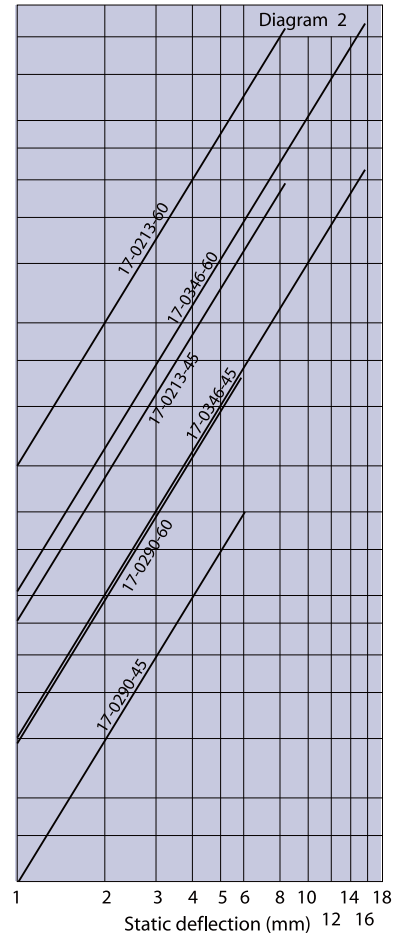
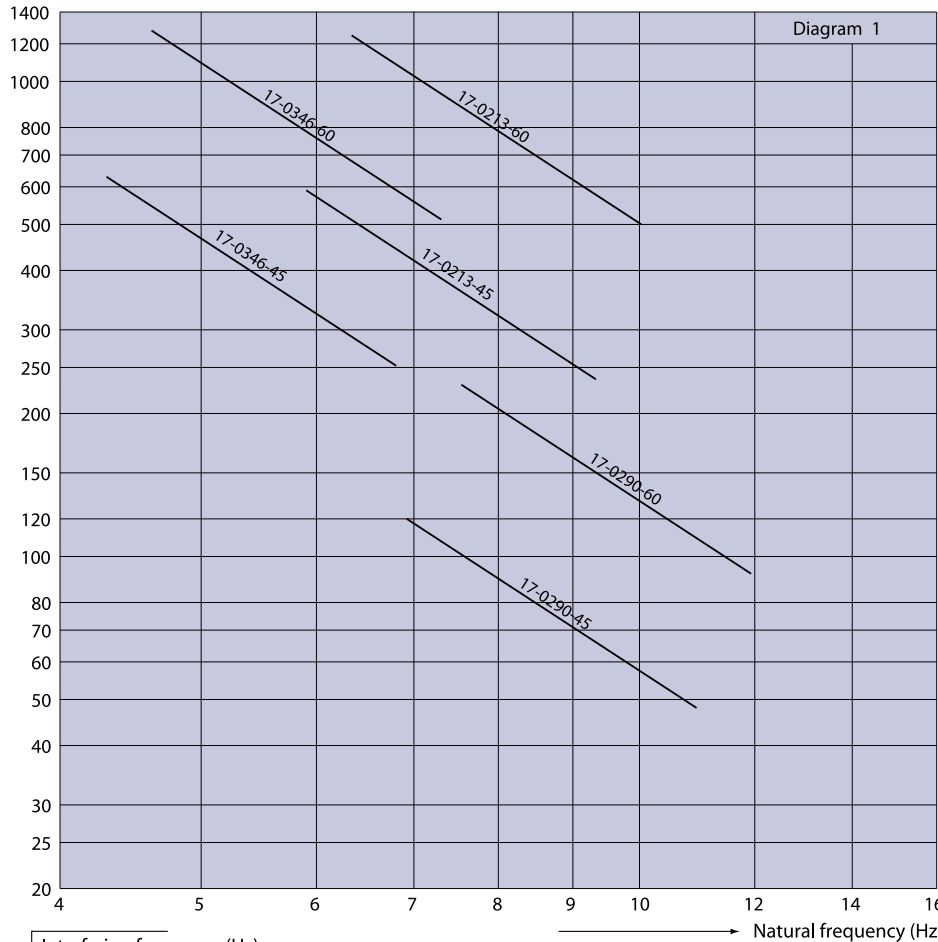

To select correct mounting, following data are needed:

- 1) Load per mounting (kg)
- 2) Interfering frequency (Hz)
(Hz = rpm / 60)

Select correct load line in diagram 1 and correct interference line in diagram 3. The load line intersects with required type of mounting. Connect this intersection point vertically down to the interference line in diagram 3. Here, on the sloping curve, the isolation degree is indicated. For static deflection, see diagram 2.

