



**Features**

Type EH is designed primarily for mobile applications where high dynamic and shock forces are encountered.

Dynamic vertical movements in both the directions are restricted and excellent horizontal stability is provided.

Stress on brackets are optimized while at the same time obtaining vibration isolation and shock absorption.

The function of EH includes features as:

- ▼ Fail-safe installation
- ▼ Simple design – easy to install
- ▼ Wide load range, 80 to 450 kg
- ▼ Dynamic efficiency in all directions
- ▼ Attenuation of structure-borne noise
- ▼ Accommodation of misalignment and distortion

**Novibra® type EH™**

Type EH mountings are designed to achieve effective vibration isolation on engines, operator cabins and other ancillary units.

Typical applications can be found in the following areas:

- ▼ Military vehicles
- ▼ Agricultural vehicles
- ▼ Off-road equipment
- ▼ Construction equipment
- ▼ Transport machinery
- ▼ Industrial mobile machinery

Max tightening torque:

- ▼ EH 4850: 40 Nm
- ▼ EH 6463: 80 Nm
- ▼ EH 9075: 200 Nm

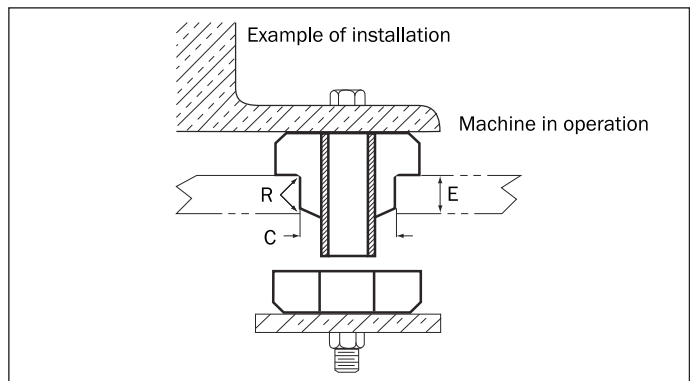
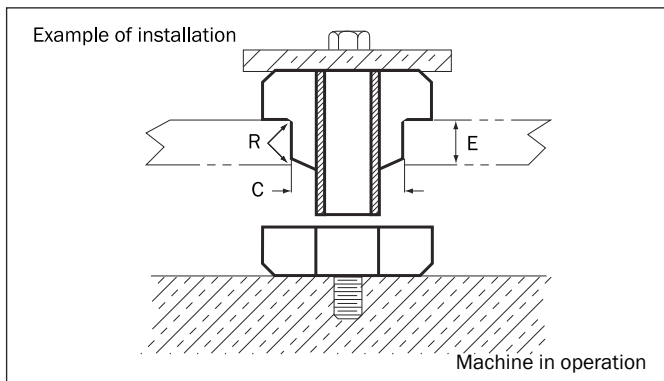
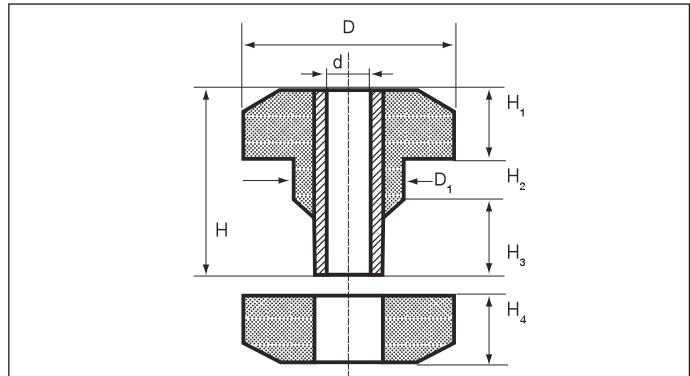

| Type        | Drawing no. | Dimensions in mm |          |                  |    |     |    |    |    |    |    | Top & Bottom Washer |        |               |  |    |  |          |  |
|-------------|-------------|------------------|----------|------------------|----|-----|----|----|----|----|----|---------------------|--------|---------------|--|----|--|----------|--|
|             |             | C                |          | E                |    | R   |    | H  |    | H1 |    | H2                  |        | H3            |  | H4 |  |          |  |
| EH4850      | 19-0213-1   | 31,0             |          | 15,0             |    | 1,5 |    | 50 |    | 20 |    | 10                  |        | 20            |  | 20 |  | 20-00416 |  |
| EH6463      | 19-0214-1   | 39,0             |          | 22,0             |    | 2,3 |    | 62 |    | 23 |    | 14                  |        | 25            |  | 23 |  | 20-00532 |  |
| EH9075      | 19-0727-1   | 56,5             |          | 28,0             |    | 3,0 |    | 73 |    | 25 |    | 19                  |        | 29            |  | 25 |  | 20-00533 |  |
| Drawing no. |             | Part no.         |          | Dimensions in mm |    |     |    |    |    |    |    |                     |        | Max load (Kg) |  |    |  |          |  |
|             |             | 40°IRH           | 60°IRH   | d                | D  | D1  | H  | H1 | H2 | H3 | H4 | 40°IRH              | 60°IRH |               |  |    |  |          |  |
| EH4850      | 19-0213-1   | 20-00621         | 20-00620 | 13,0             | 50 | 32  | 50 | 20 | 10 | 20 | 20 | 80                  | 130    |               |  |    |  |          |  |
| EH6463      | 19-0214-1   | 20-00619         | 20-00618 | 17,0             | 64 | 40  | 62 | 23 | 14 | 25 | 23 | 120                 | 260    |               |  |    |  |          |  |
| EH9075      | 19-0727-1   | –                | 20-00616 | 23,0             | 89 | 58  | 73 | 25 | 19 | 29 | 25 | 260                 | 450    |               |  |    |  |          |  |

Note: The natural frequencies and degrees of isolation are based on dynamic characteristics of the mountings.

Load per mounting (kg)

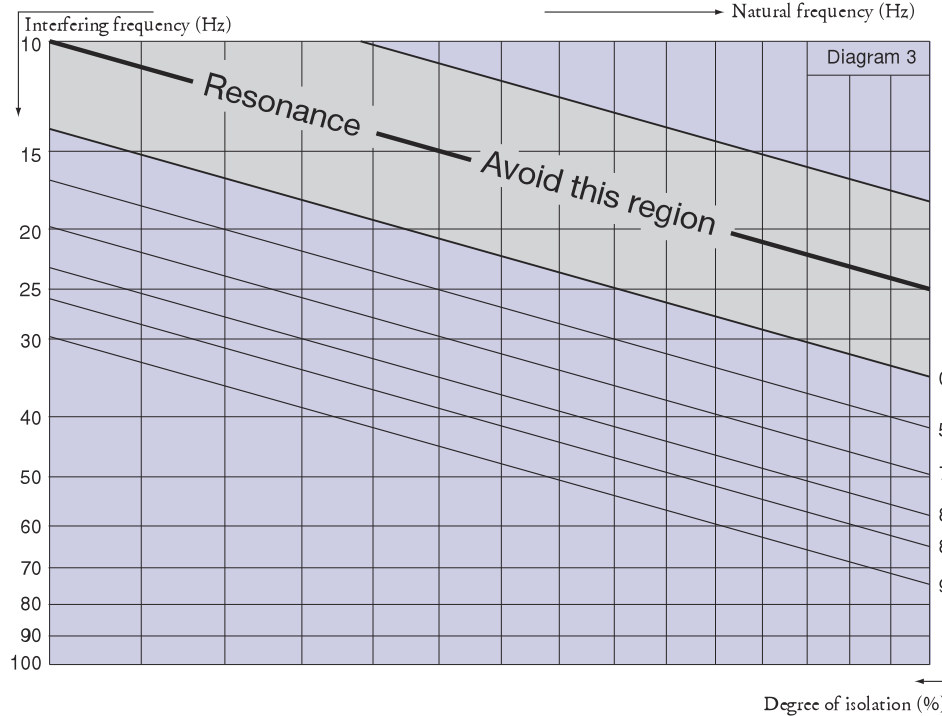
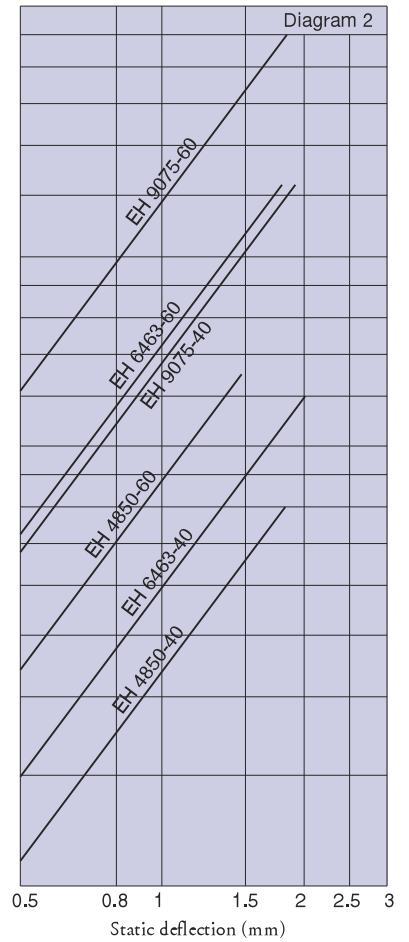
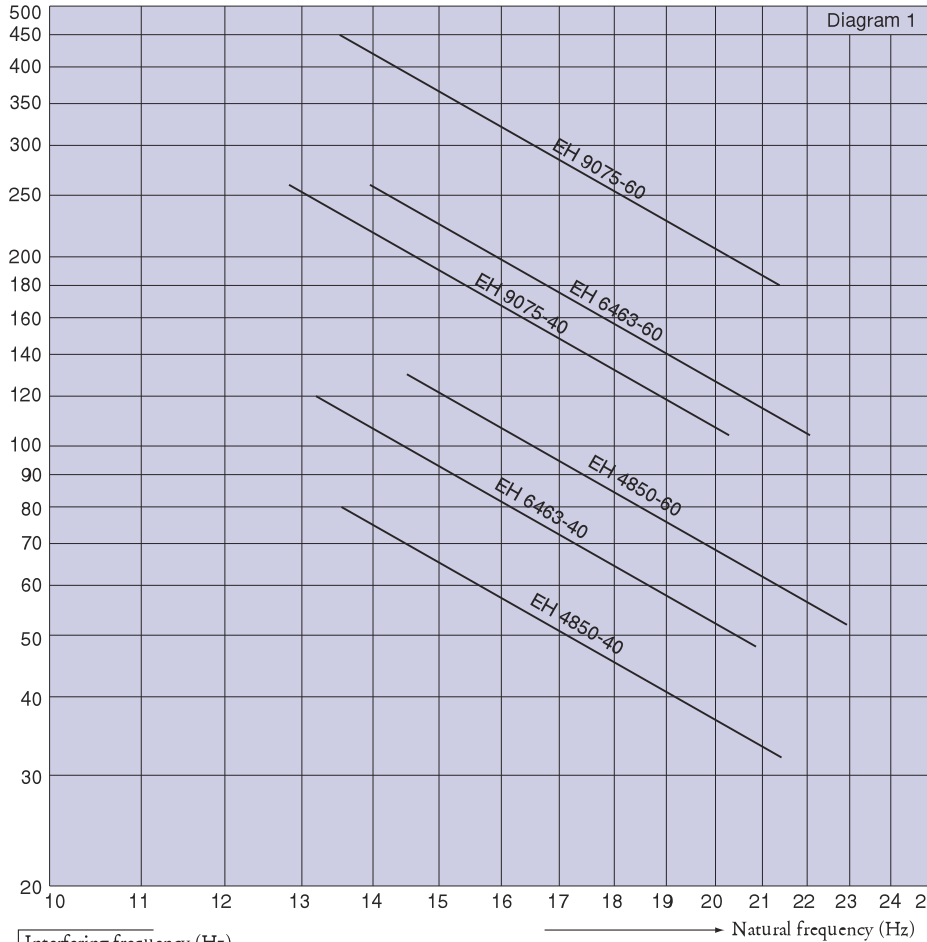

To select correct mounting, following data are needed:

- 1) Load per mounting (kg)
- 2) Interfering frequency (Hz)  
(Hz = rpm / 60)

Select correct load line in diagram 1 and correct interference line in diagram 3. The load line intersects with required type of mounting.

Connect this intersection point vertically down to the interference line in diagram 3. Here, on the sloping curve, the isolation degree is indicated.

For static deflection, see diagram 2.

