

Equi-frequency™ Mountings



Features

Each design has substantially the same stiffness in vertical and horizontal directions. Load range 11 kg to 54 kg. Can be used as small anti-shock mounting when static loadings are derated.

Metalastik® type Equi-Frequency™ Mountings

General purpose low profile mounting for use where space is restricted. Suitable for stationary applications. May also be used to protect delicate or sensitive equipment from external shock or disturbances.

Typical applications include:

- ▼ Small fan sets
- ▼ Instrument panels
- ▼ Small vacuum pumps
- ▼ Small reciprocating engines

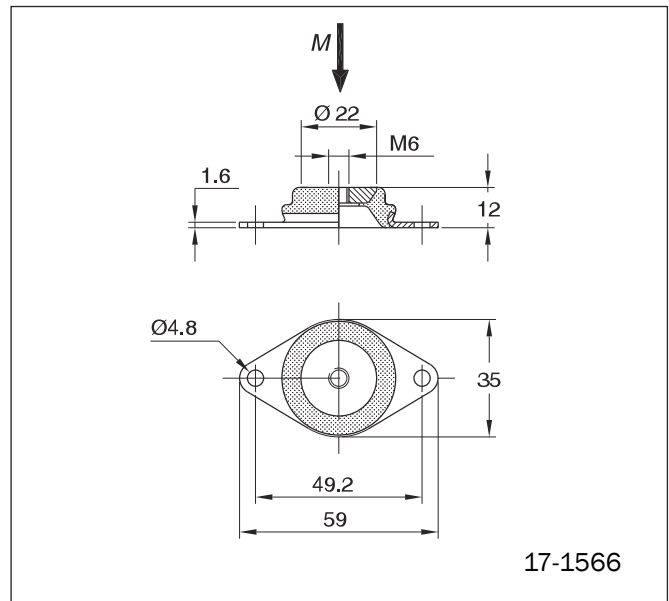
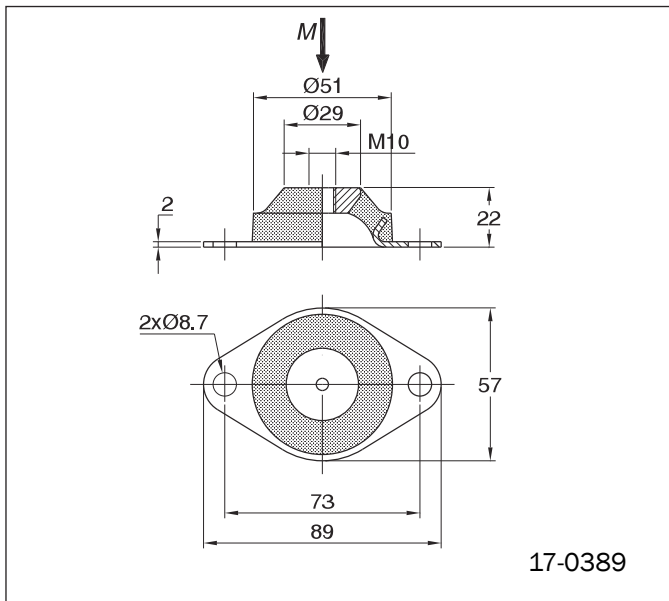

Drawing no.	Part no.	M-Max (Kg)	Weight (Kg)
17-1566	10-00529	11	0,024
17-1566	10-00530	22	0,024
17-0389-5	10-00406	27	0,10
17-0389-5	10-00407	54	0,10

Equi-frequency™ Mountings

Note: The natural frequencies and degrees of isolation are based on dynamic characteristics of the mountings.

Load per mounting (kg)

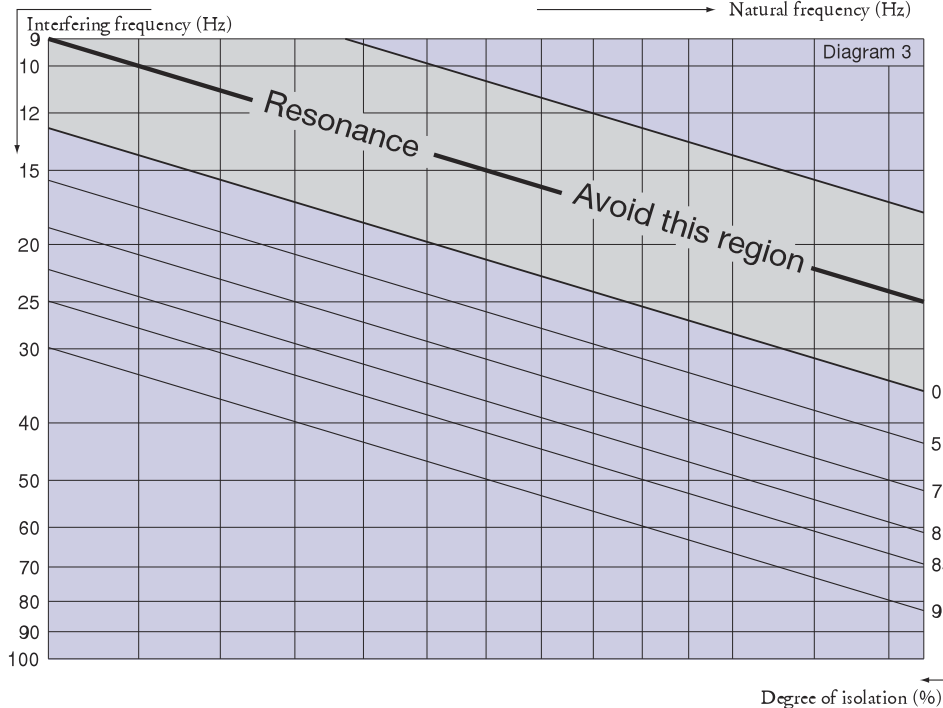
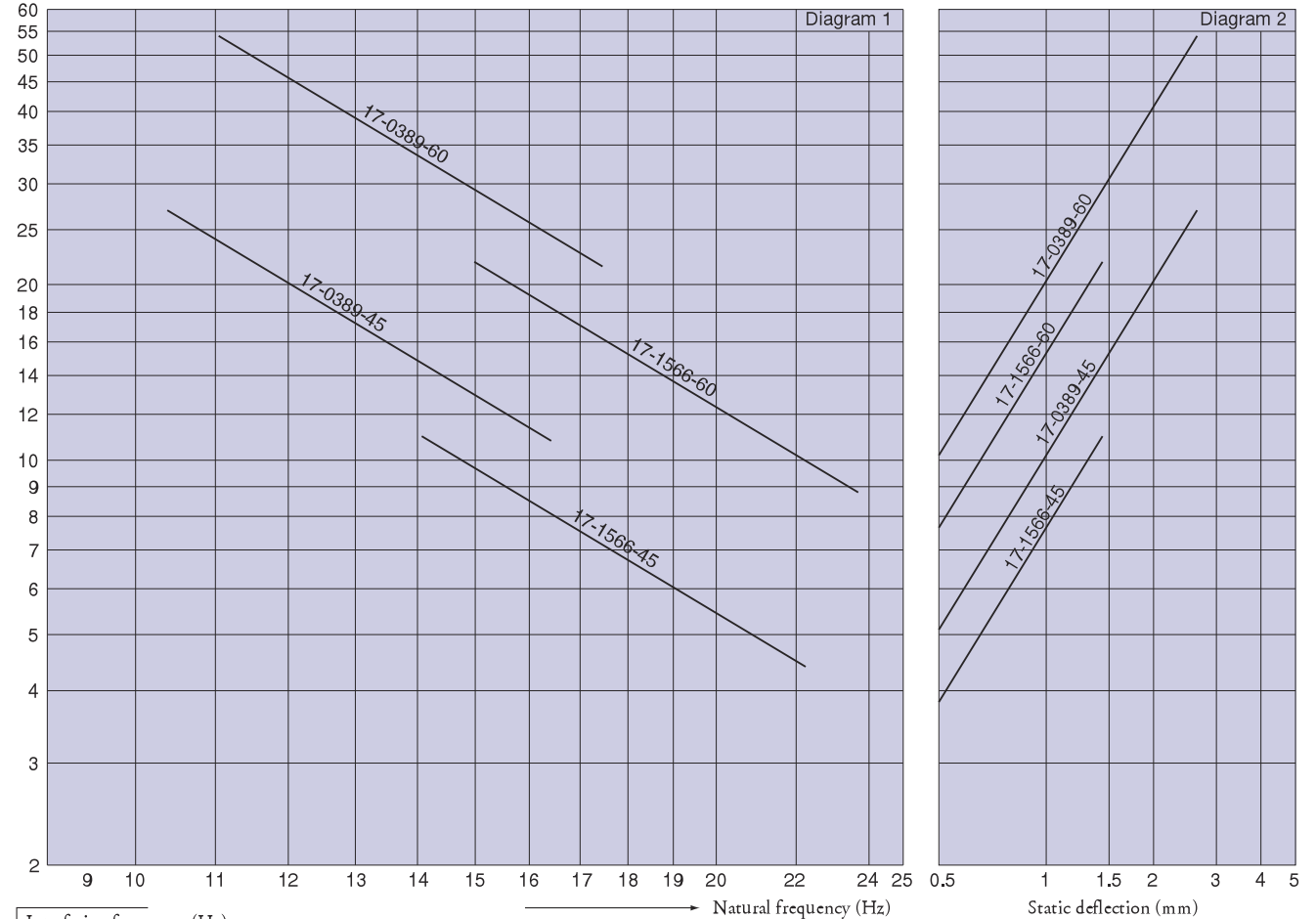

To select correct mounting, following data are needed:

- 1) Load per mounting (kg)
- 2) Interfering frequency (Hz) (Hz = rpm / 60)

Select correct load line in diagram 1 and correct interference line in diagram 3. The load line intersects with required type of mounting. Connect this intersection point vertically down to the interference line in diagram 3. Here, on the sloping curve, the isolation degree is indicated. For static deflection, see diagram 2.

