

Low Frequency Mountings

Features

These anti-vibration mountings are designed to give large deflection for small loads and are used to protect suspended equipment against vibration and impact.

Low Frequency Mountings are available in three sizes and two grades of rubber hardness.



Novibra® type Low Frequency Mountings

Novibra® type Low Frequency are designed for shear as well as compressive loads. Continual tensile load should be avoided.

Ideal for applications as:

- ▼ Light instruments
- ▼ Light fans and compressors
- ▼ Computer and electronic units
- ▼ Shock mounting for light applications

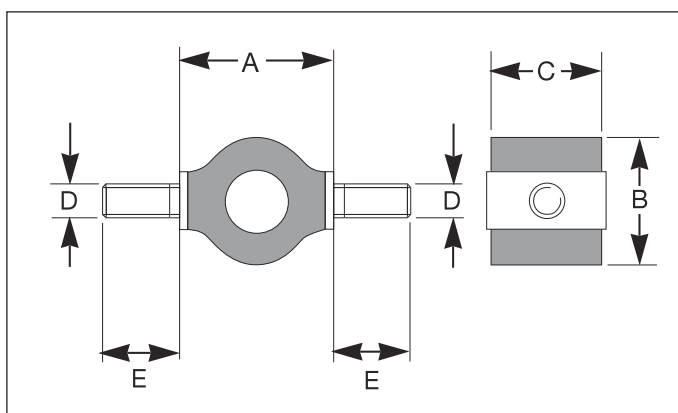
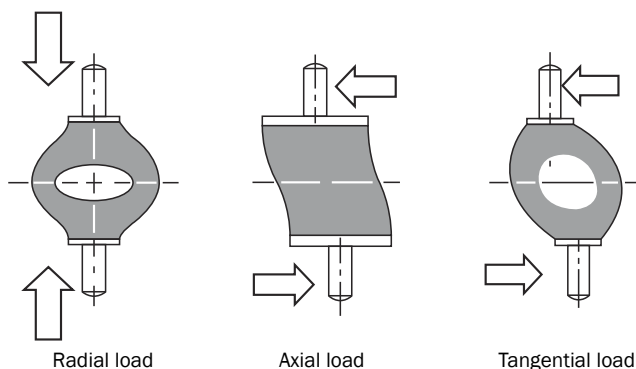

Drawing no.	Part no.		Dimensions in mm					45° IRH Max Load			60° IRH Max Load		
	45° IRH	60° IRH	A	B	C	D	E	Radial(N)	Axial(N)	Tangential(N)	Radial(N)	Axial(N)	Tangential(N)
17-1394	20-00017	20-00018	17	14	13	M4	10	14	4	2,5	18	5	3,5
17-1395	20-00020	20-00021	30	25	19	M5	14	30	10	8	55	15	15
17-1396	20-00022	20-00023	38	35	25	M6	15	85	30	25	125	45	35

Low Frequency Mountings

Note: The natural frequencies and degrees of isolation are based on dynamic characteristics of the mountings.

Load per mounting (kg)

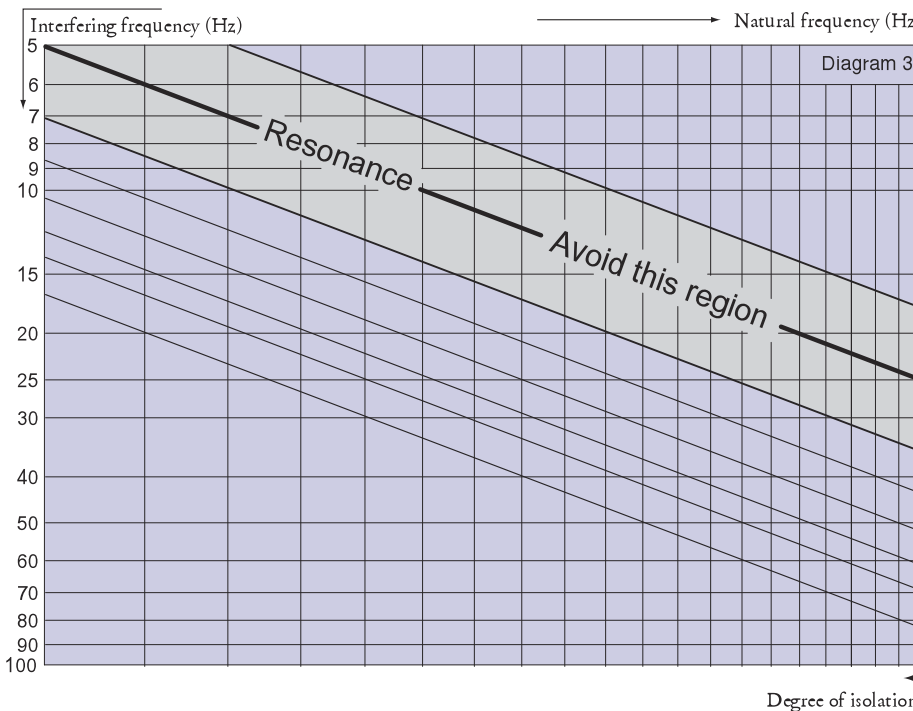
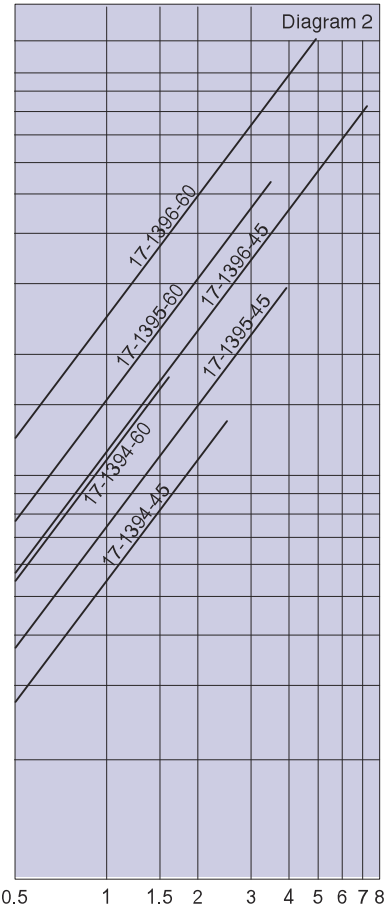
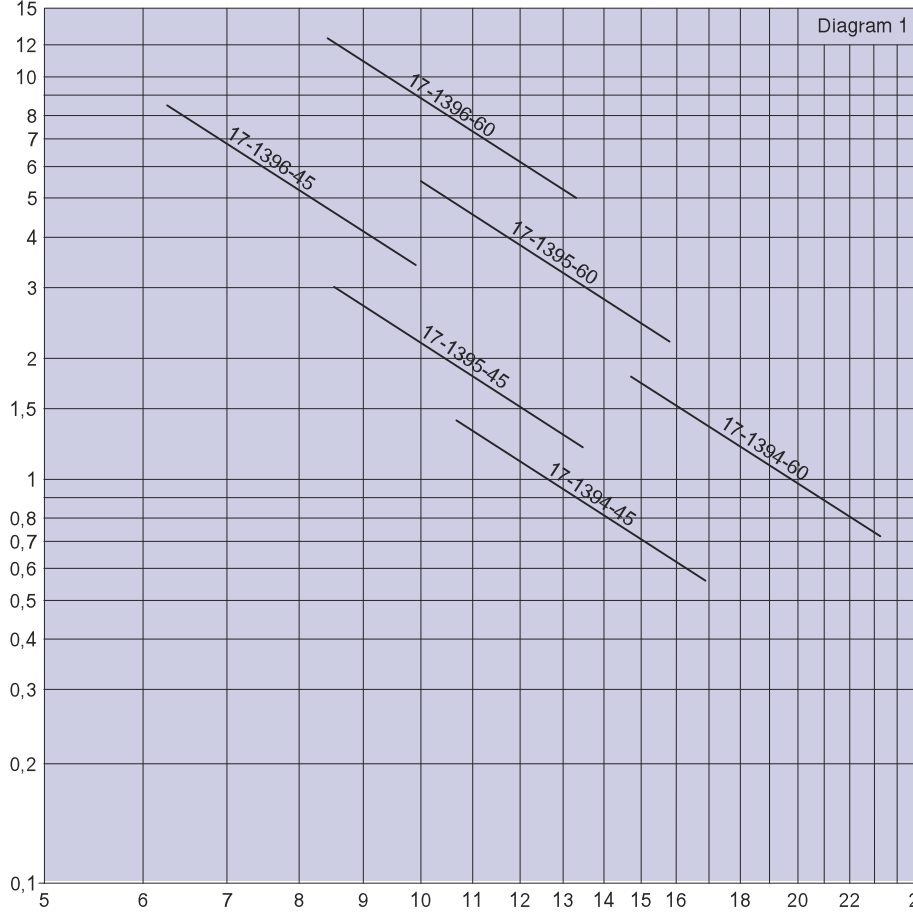

To select correct mounting, following data are needed:
 1) Load per mounting (kg)
 2) Interfering frequency (Hz)
 (Hz = rpm / 60)
 Select correct load line in diagram 1 and correct interference line in diagram 3. The load line intersects with required type of mounting.
 Connect this intersection point vertically down to the interference line in diagram 3. Here, on the sloping curve, the isolation degree is indicated.
 For static deflection, see diagram 2.

