

## Features

Novibra® type M<sup>TM</sup> is specifically designed to give large deflection at low loads. Although the mount design allows high deflection, the mountings are compact in weight and easy to install.

Its unique construction and the latest production methods make Novibra® type M<sup>TM</sup> a high performance antivibration mounting having a number of advantages:

- ▼ Tight tolerances on dynamic stiffness rate for accurate vibration calculations.
- ▼ Wide load rating options, 3.5–2500 kg.
- ▼ Corrosion protected to cope with arduous environments on land or marine applications (Fe/Zn8C2 as per ISO 2081).
- ▼ Clear and durable product marking so that mountings can be identified even after several years in operation.

When using M<sup>TM</sup> mount together with the height adjuster HA, it is necessary to use a washer. The diameter of the washer must be 20% larger than the diameter of the upper plate (D).

Specific fields of application are:

- ▼ Fans
- ▼ Pumps
- ▼ AC-units
- ▼ Ventilators
- ▼ Refrigerators
- ▼ Compressors
- ▼ Electric motors
- ▼ Weighing scales
- ▼ Test cell equipment
- ▼ Vibratory screens
- ▼ Noise control units
- ▼ Packaging application
- ▼ Food processing equipment
- ▼ Powder handling machinery



**Novibra® type M<sup>TM</sup>**

Type M<sup>TM</sup> is ideal for applications involving isolation of low frequency vibrations in all planes. Also suitable for shock attenuation due to the designed ability to offer large deflection. Provides passive vibration isolation on electronic instruments, measuring equipment and test cells.

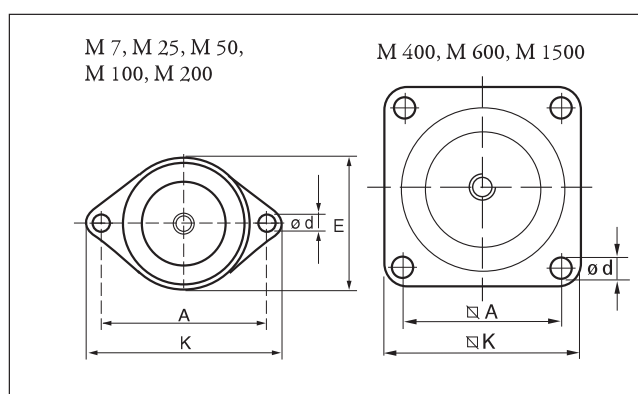
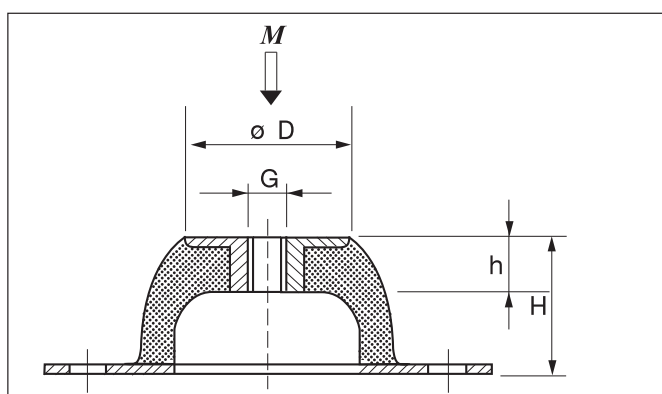

Type	Part no.		Dimensions in mm								M-Max(Kg)		Weight (Kg)
	40° IRH	60° IRH	D	E	A	K	H	h	d	G	40° IRH	60° IRH	
M7	10-00139	10-00140	18	43	50	64	20	7	7,0	M6	3,5	9	0,02
M25	10-00094	10-00095	33	56	66	85	25	11	8,0	M8	20	50	0,07
M50	10-00096	10-00097	45	76	92	114	35	14	10,0	M10	40	80	0,16
M100	10-00100	10-00099	53	96	110	136	40	15	11,5	M10	70	150	0,26
M200	10-00102	10-00103	58	101	124	151	45	13	11,5	M10	130	220	0,42
M400	10-00104	10-00105	78		120	150	63	18	14,5	M12	280	500	1,06
M600	10-00080	10-00081	100		160	200	85	25	14,5	M16	380	750	2,35
M1500	10-00082	10-00083	186		250	310	160	43	18,0	M24	1400	2500	9,43

Note: The natural frequencies and degrees of isolation are based on dynamic characteristics of the mountings.

Load per mounting (kg) M25 - M1500

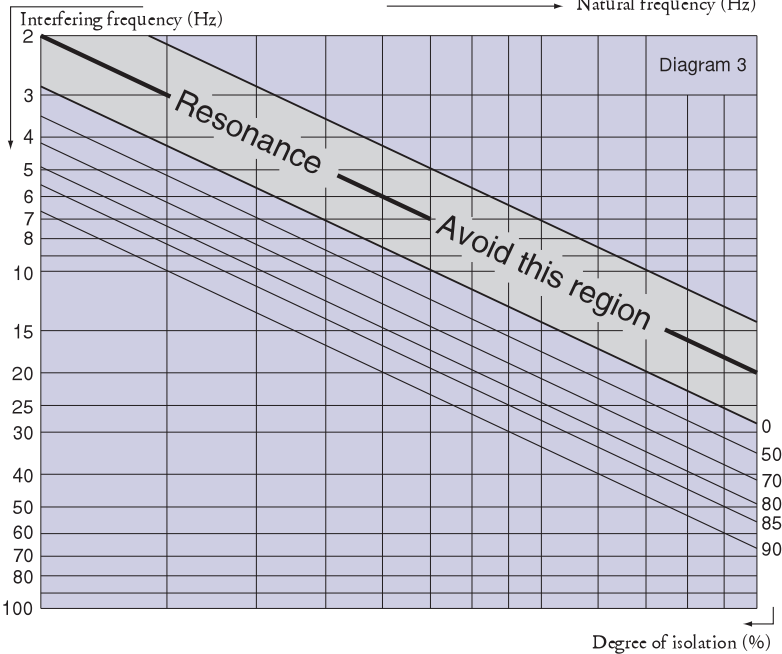
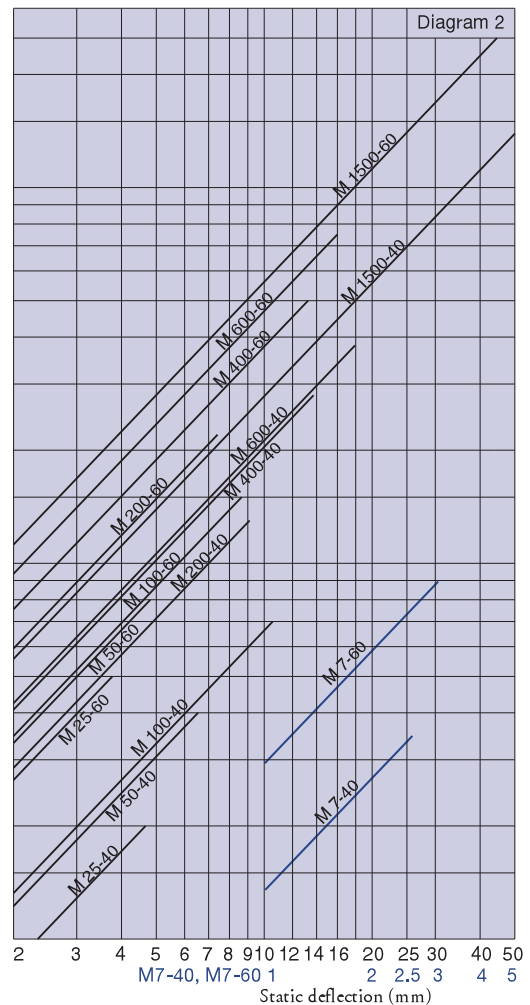
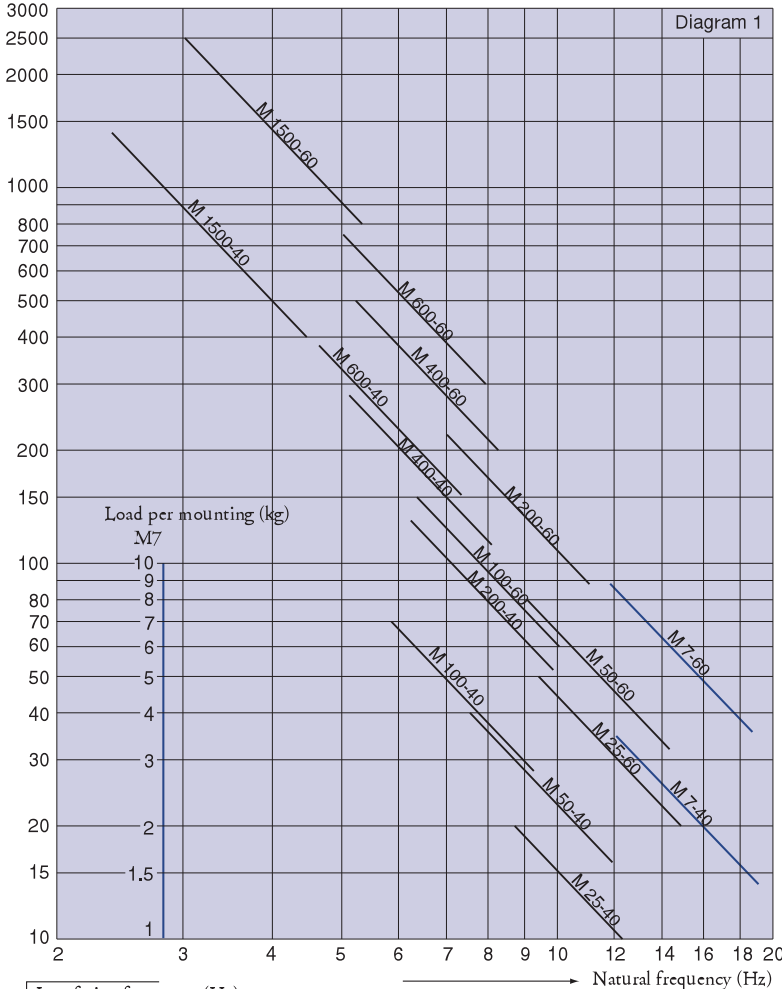

To select correct mounting, following data are needed:  
 1) Load per mounting (kg)  
 2) Interfering frequency (Hz)  
 (Hz = rpm / 60)  
 Select correct load line in diagram 1 and correct interference line in diagram 3.  
 The load line intersects with required type of mounting.  
 Connect this intersection point vertically down to the interference line in diagram 3.  
 Here, on the sloping curve, the isolation degree is indicated.  
 For static deflection, see diagram 2.

