

Features

The MDS™ mounting is easy to install based on a 2 part single bolt installation. There is no requirement for radius or chamfered installation hole and a steel flange prevents rubber wear at the bracket interface. The bonded steel snubbing cup limits vertical movements and prevents excessive strain in rubber. The cup is encapsulated in rubber to prevent corrosion.

A rubber rim holds the lower mount half in the hole during assembly.

- ▼ Vertical dynamic snubbing +/- 6 mm.
- ▼ Horizontal dynamic snubbing +/- 3 mm.
- ▼ Static vertical load range 70-200 kg.
- ▼ Deflection at max static load 2.5 mm.
- ▼ Axial to radial stiffness ratio 1.5:1.

TYPICAL STATIC AXIAL (VERTICAL) STIFFNESS MDS 80/3820

(Assembled in pairs, with upper and lower washers 19-20 mm thick plate, 38 mm dia. hole)

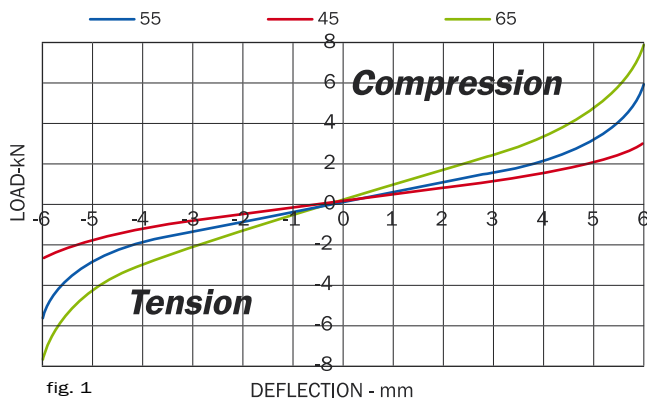

fig. 1 DEFLECTION - mm



Trellextreme® type MDS™

The MDS™ mounts is designed to take high dynamic shock loads but to limit mount movements in all directions, MDS™=Multi Directional Snubbing.

In the static working load range, the MDS™ mounts have linear stiffness characteristics allowing easy prediction of mount deflection and isolation performance. (see fig. 1)

- ▼ Typical applications:
Engines and small cabs on off-highway vehicles.

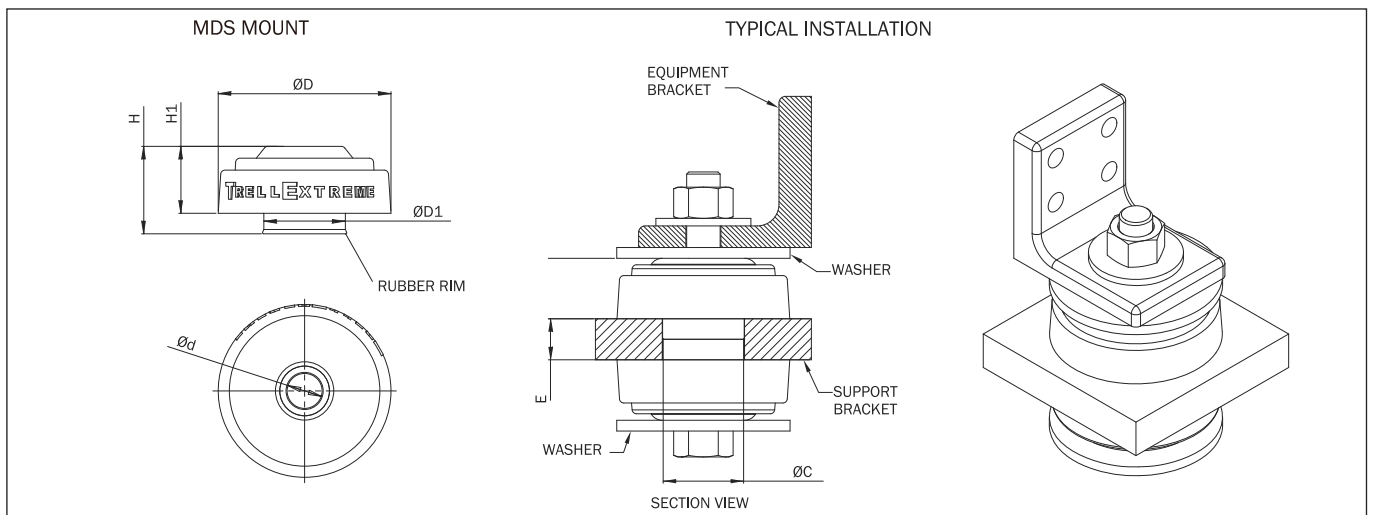

See below table showing principal sizes and models. Part listed are a selection of a wider range, details of which are available on request. Please contact our Off Highway Applications department for further advise. More product and model information are available upon request.

Type	Drawing no.	Part no.	Dimensions in mm							Bolt Size	Max. Bolt Torque(Nm)	Max Load (Kg)
			d	D	D1	H	H1	C	E			
MDS80-45	17-2280	10-01802	16,2	80	37,8	40,5	31	38	19/20	M16	240	90
MDS80-55	17-2280	10-01803	16,2	80	37,8	40,5	31	38	19/20	M16	240	140
MDS80-65	17-2280	10-01804	16,2	80	37,8	40,5	31	38	19/20	M16	240	200
MDS66-45	17-2243	10-01799	18,8	66	39,8	38	28,5	40	19/20	M16	240	70
MDS66-55	17-2243	10-01800	18,8	66	39,8	38	28,5	40	19/20	M16	240	120
MDS66-65	17-2243	10-01801	18,8	66	39,8	38	28,5	40	19/20	M16	240	170

Note: The natural frequencies and degrees of isolation are based on dynamic characteristics of the mountings.

Load per mounting (kg)

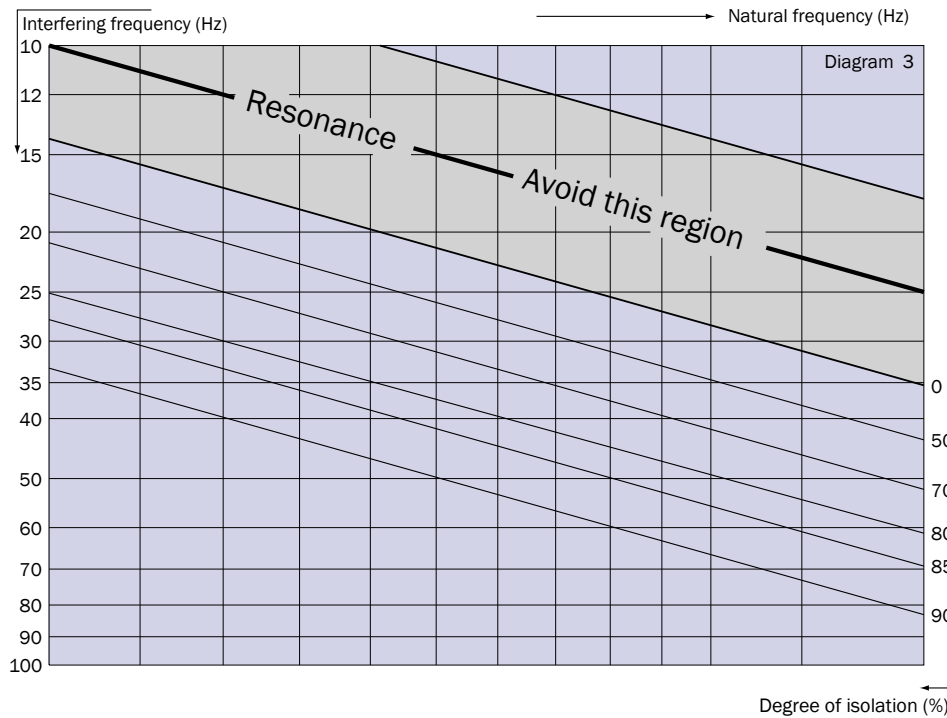
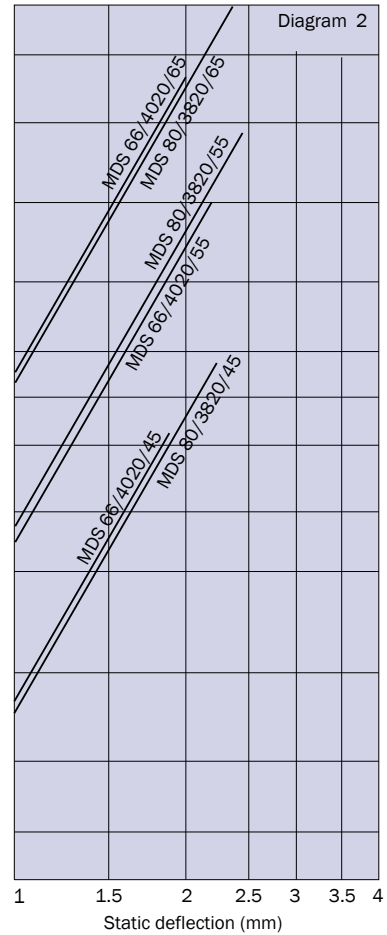
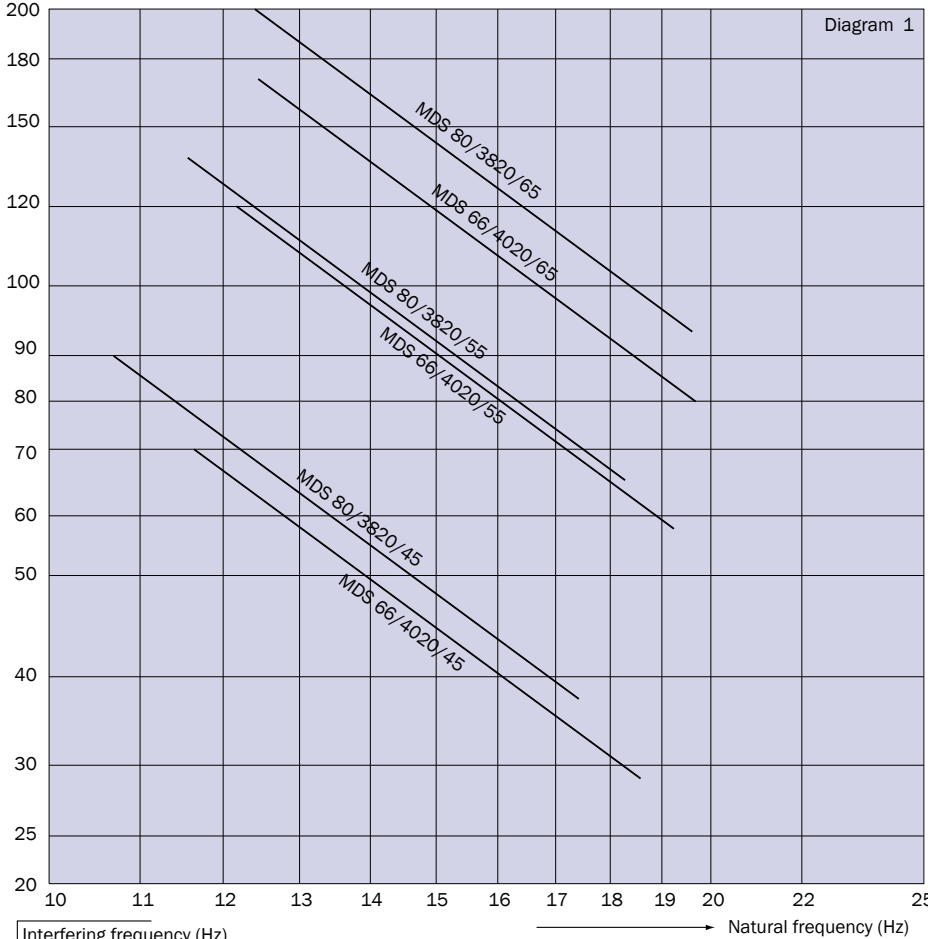

To select correct mounting, following data are needed:
 1) Load per mounting (kg)
 2) Interfering frequency (Hz)
 (Hz = rpm / 60)
 Select correct load line in diagram 1 and correct interference line in diagram 3. The load line intersects with required type of mounting.
 Connect this intersection point vertically down to the interference line in diagram 3. Here, on the sloping curve, the isolation degree is indicated.
 For static deflection, see diagram 2.

