

# Rectangular SAW™ Mountings



## Features

Rectangular SAW mountings are also known as 'Sandwich' mountings because they feature a rubber section sandwiched between plates of metal.

This arrangement allows a large difference between the compression and shear stiffnesses, thus providing the potential to 'tune' a mounting system by rotating the mountings.

These mountings are commonly installed in a 'Vee' formation to utilize this feature.

The Rectangular SAW Mountings has the following features:

- ▼ Available with plate or stud fixings.
- ▼ Can be loaded in compression or shear, or a combination of both, for example in a 'Vee' arrangement.
- ▼ Can be manufactured with or without interleaves to change the ratio of shear to compression stiffness.

## Metalastik® type Rectangular SAW™

Widely used for suspending engines on road vehicles and may also be employed as springs for vibratory equipment.

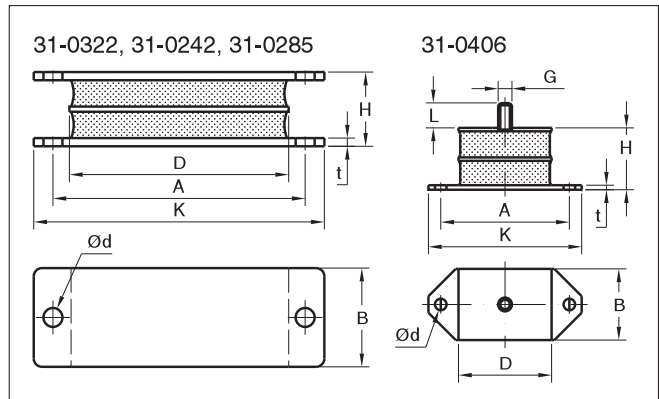

Drawing no.	Part no.	Dimensions in mm									Max Load in Compression ((Kg)	Max Load in Shear (Kg)	Weight (Kg)
		A	B	K	H	D	d	t	G	L			
31-0322-45	10-00658	89	57	108	43	63,5	11	5			180	50	0,65
31-0322-60	10-00659	89	57	108	43	63,5	11	5			360	75	0,65
31-0242-45	10-00648	146	57	168	43	127	11	5			450	120	1,1
31-0242-60	10-00651	146	57	168	43	127	11	5			900	150	1,1
31-0242-70	10-00652	146	57	168	43	127	11	5			1050	150	1,1
31-0406-45	10-00661	74,5	41	89	36	54	6,5	2,5	M8	14	90	40	0,23
31-0406-60	10-00971	74,5	41	89	36	54	6,5	2,5	M8	14	180	70	0,23
31-0406-70	10-00663	74,5	41	89	36	54	6,5	2,5	M8	14	250	90	0,23
31-0285-45	10-00656	146	57	168	43	127	11	5			275	150	0,9
31-0285-60	10-00657	146	57	168	43	127	11	5			546	150	0,9

# Rectangular SAW™ Mountings

Note: The natural frequencies and degrees of isolation are based on dynamic characteristics of the mountings.

