



### Features

Novibra® type SAW™ mountings consist of a cylindrical shaped rubber section with integrally bonded interleaf metal plates bonded to two square heavy duty outer metal fixing plates. Designed for large compressive forces with minimum deformation, while providing low shear stiffness rates.

The combination of a stable low installation height, high compressive strength and low shear stiffness makes Novibra® type SAW™ a versatile high performance anti-vibration mounting. Ease of installation due to 4 clearance holes in each fixing plate.

By connecting 2 SAW-elements in series, i.e. one on top of the other, an increased isolation efficiency is achieved in both shear and compression planes. Where larger deflections are required in the vertical plane, Novibra® type SAW™ mountings are mounted at a calculated angle configuration to provide the optimum spring rate.

### Novibra® type SAW™

Novibra® elements type SAW is heavy duty mountings for static and shock loads in compression. Provides high isolation in the horizontal shear direction.

Typical fields of application are:

- ▼ Mills
- ▼ Grinders
- ▼ Screens
- ▼ Crushers
- ▼ Edge runners
- ▼ Vibratory rollers
- ▼ Hoppers and feeders
- ▼ Other very heavy machines and equipment

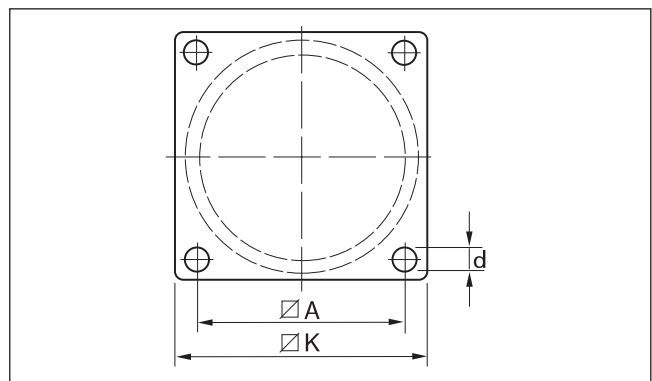
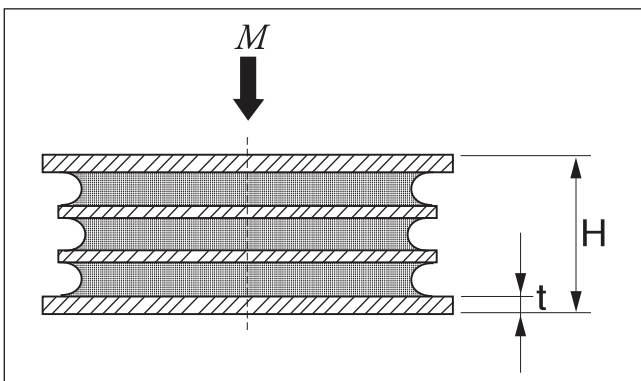
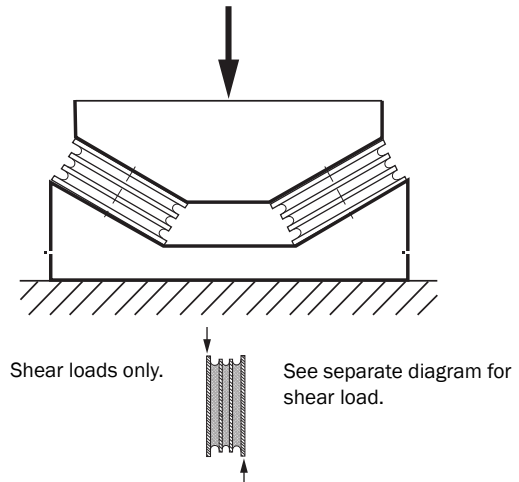

Type	Part no.		Dimensions in mm					M-Max (Kg)		Weight (Kg)
	40°IRH	60°IRH	A	K	H	d	t	40°IRH	60°IRH	
SAW 125	10-00141	10-00142	118	148	52	13,5	5	2250	4500	2,6
SAW 150	10-00143	10-00144	136	166	63	13,5	6	3750	7500	4,1
SAW 200	10-00075	10-00076	184	220	82	17,0	8	6000	12000	9,2
SAW 300	10-00077	10-00078	270	310	120	22,0	10	15000	30000	27,0

Note: The natural frequencies and degrees of isolation are based on dynamic characteristics of the mountings.

Load per mounting (kg)

Horizontal vibration Vertical load      Vertical vibration Vertical load

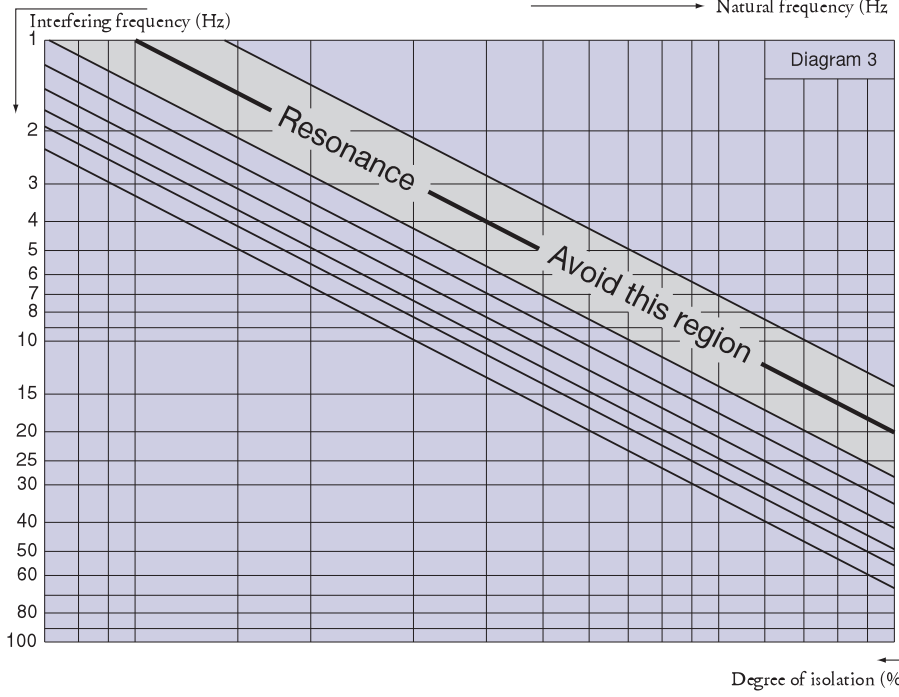
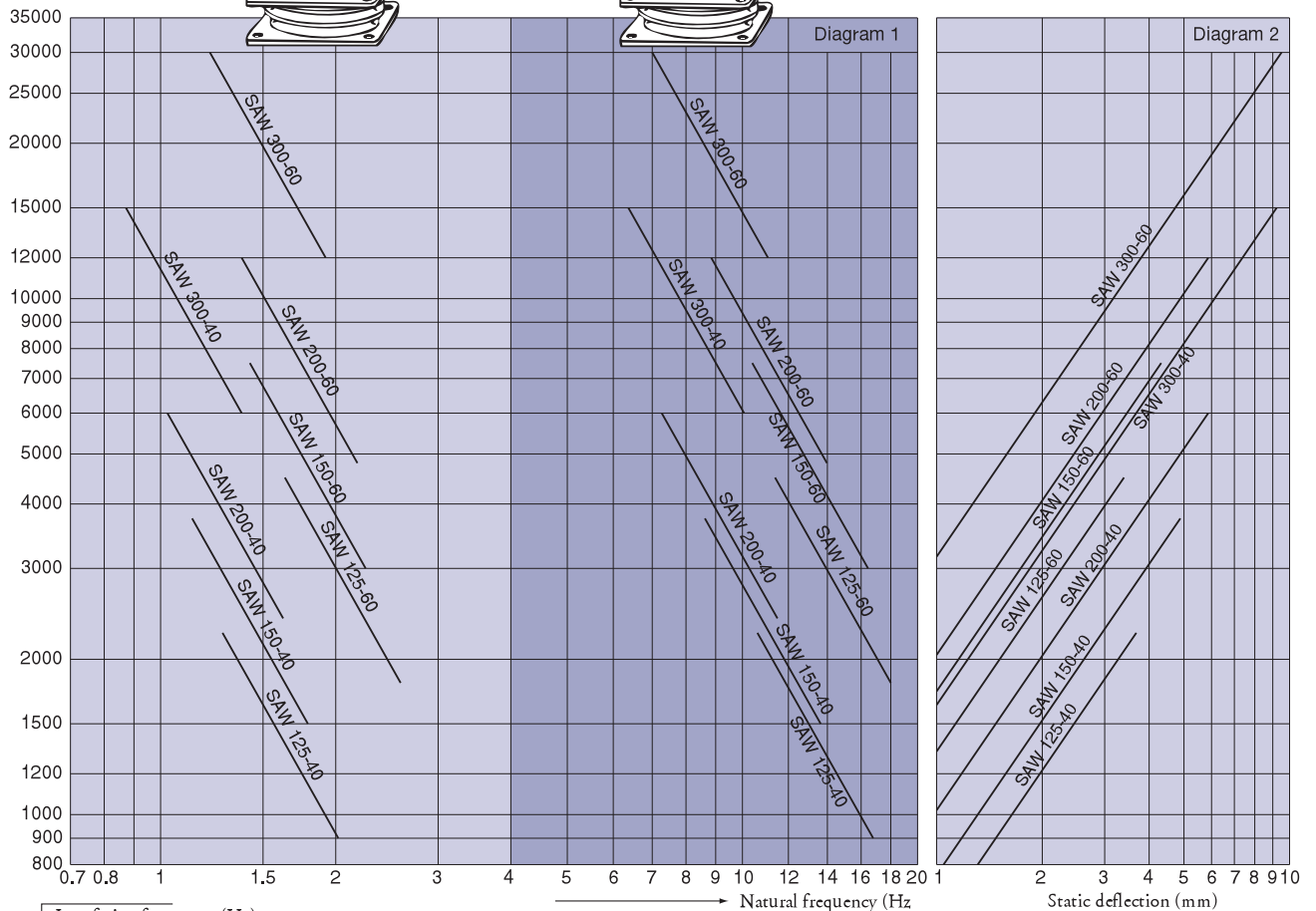

To select correct mounting, following data are needed:  
 1) Load per mounting (kg)  
 2) Interfering frequency (Hz) (Hz = rpm / 60)  
 Select correct load line in diagram 1 and correct interference line in diagram 3. The load line intersects with required type of mounting.  
 Connect this intersection point vertically down to the interference line in diagram 3. Here, on the sloping curve, the isolation degree is indicated.  
 For static deflection, see diagram 2.

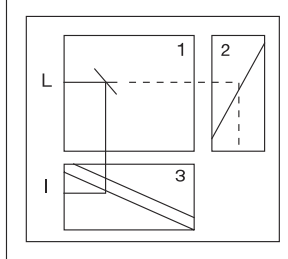

Note: The natural frequencies and degrees of isolation are based on dynamic characteristics of the mountings.

This page refers to shear load characteristics only!

Fmax (Kg)	40° IRH	60° IRH
SAW 125	240	570
SAW 150	330	850
SAW 200	600	1200
SAW 300	1575	3150

Load per mounting (kg)

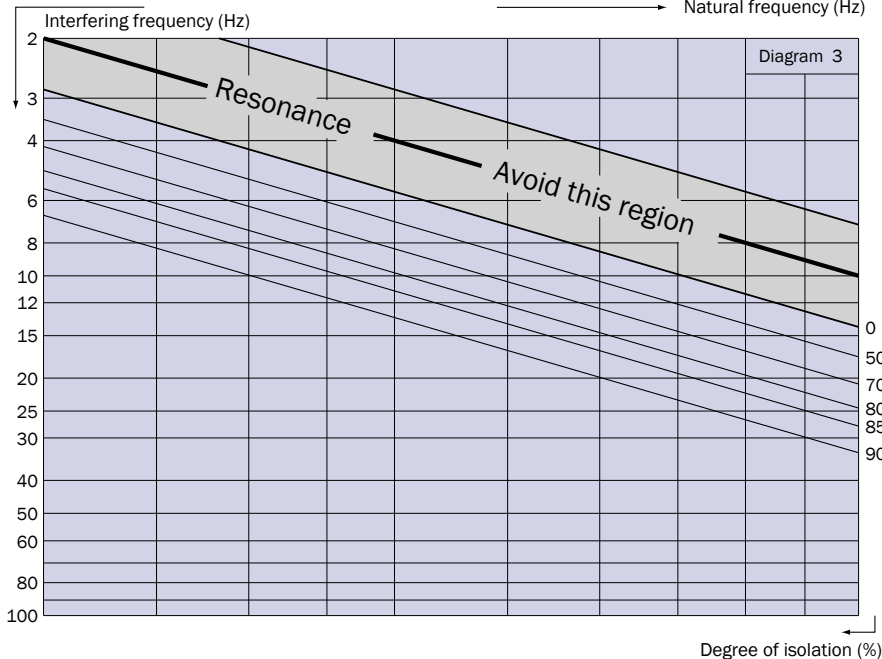
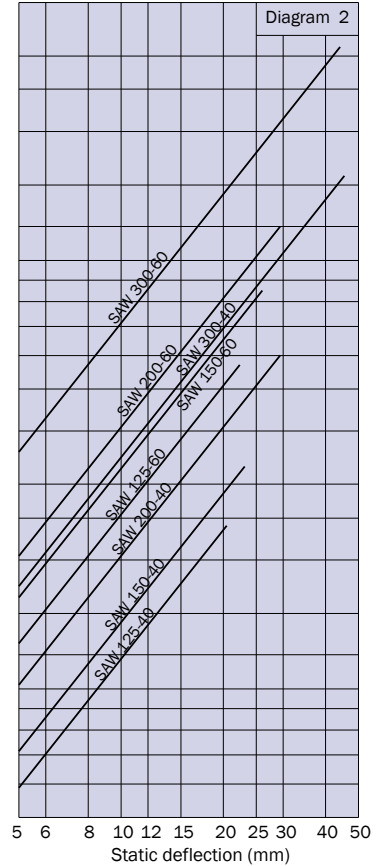
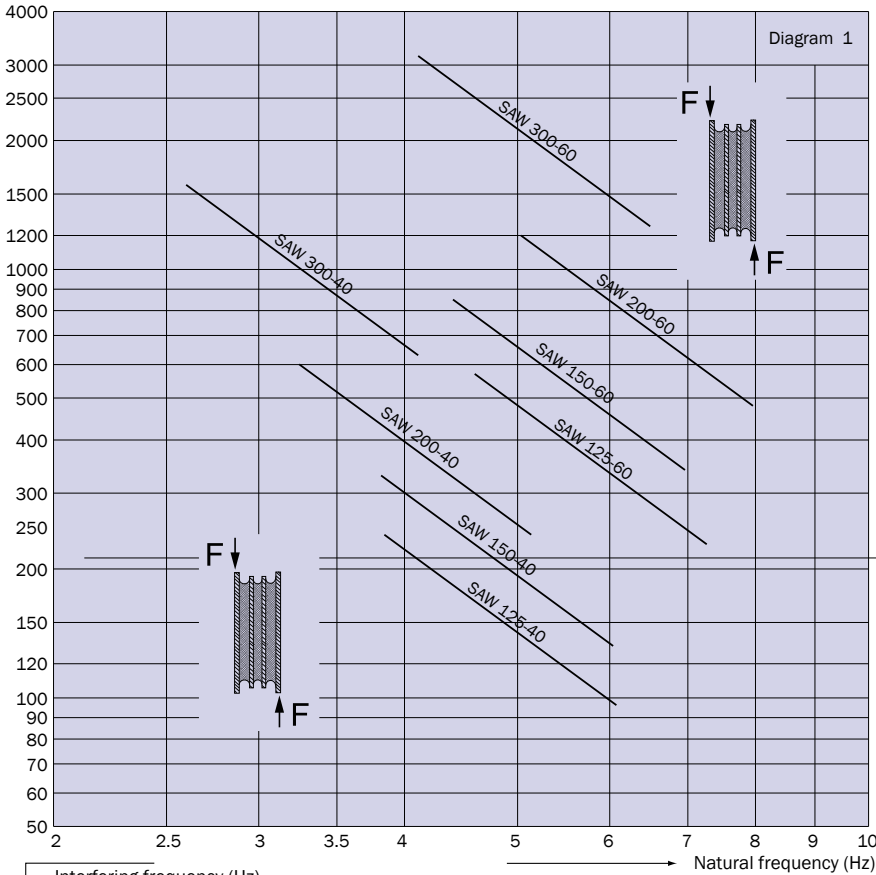

To select correct mounting, following data are needed:  
 1) Load per mounting (kg)  
 2) Interfering frequency (Hz) (Hz = rpm / 60)  
 Select correct load line in diagram 1 and correct interference line in diagram 3. The load line intersects with required type of mounting. Connect this intersection point vertically down to the interference line in diagram 3. Here, on the sloping curve, the isolation degree is indicated. For static deflection, see diagram 2.

