

Two Bolt Instrumountings™



Features

These mountings are high quality products capable of protecting light equipment from vibration and shock. Two Bolt Instrumountings are available in either 45° or 60° IRH natural rubber compound. Similar to Rectangular SAW™ Mountings and Circular SAW™ Mountings, Two Bolt Instrumountings™ can be assembled in a 'Vee' arrangement for good stability and improved vibration isolation.

- ▼ Circular or hexagonal end plates for simple fitting.
- ▼ Can take up to 3 times rated load under shock conditions.
- ▼ Takes load in either shear or compression, or a combination.
- ▼ Fixing bolts threaded to within 2 pitches of the end plate.
- ▼ Up to 12 mm deflection in shear for a very soft suspension.
- ▼ Top quality bond strength for reliability and safety.

Metalastik® type Two Bolt Instrumountings™

Two Bolt Instrumountings provide a convenient and effective means of isolating vibration generated by light-weight machinery. Also used to protect instruments and light equipment from vibration and shock. They may be loaded in compression or shear depending on application requirements.

Typical applications:

- ▼ Instrument panels
- ▼ Electronic equipment
- ▼ Lightweight laboratory machines

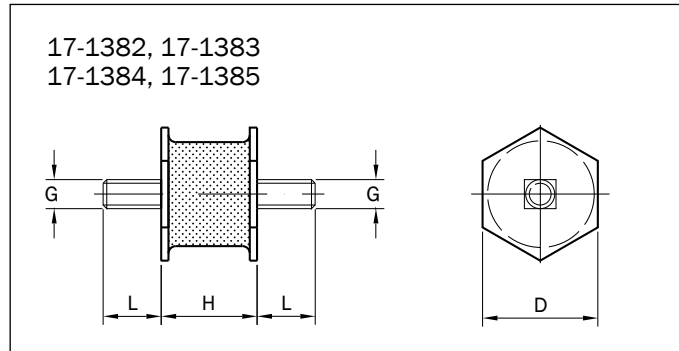
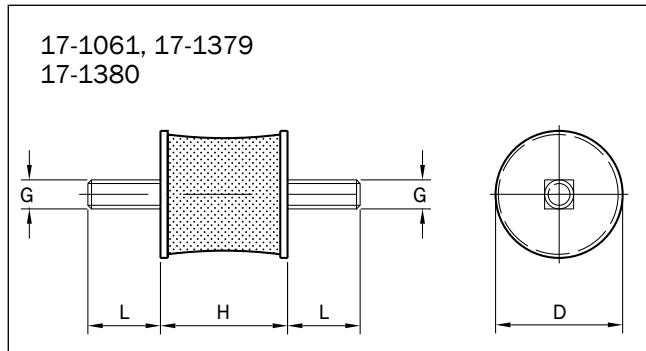

Drawing no.	Part no.	Dimensions in mm			L	Max Load in Compression (Kg)	Max Load in Shear (Kg)	Weight (Kg)
		D	H	G				
17-1061-45	10-00443	11	11	M4	10	2,4	2,3	0,005
17-1061-60	10-00444	11	11	M4	10	4,8	2,5	0,005
17-1379-45	10-00470	21	22	M6	15	7,0	5	0,02
17-1379-60	10-00471	21	22	M6	15	14	5	0,02
17-1380-45	10-00472	35	34	M8	20	16	15	0,07
17-1380-60	10-00473	35	34	M8	20	32	15	0,07
17-1382-45	10-00476	15	16	M6	15	3,8	3	0,013
17-1382-60	10-00477	15	16	M6	15	7,6	3	0,013
17-1383-45	10-00478	21	19	M8	20	8,0	6	0,03
17-1383-60	10-00479	21	19	M8	20	16	6	0,03
17-1384-45	10-00480	32	26	M8	16	15	10	0,06
17-1384-60	10-00481	32	26	M8	16	30	10	0,06
17-1385-45	10-00482	33	22	M10	25	30	14	0,11
17-1385-60	10-00483	33	22	M10	25	60	14	0,11

Two Bolt Instrumountings™

Note: The natural frequencies and degrees of isolation are based on dynamic characteristics of the mountings.

Load per mounting (kg)

Horizontal vibration Vertical load

Vertical vibration Vertical load

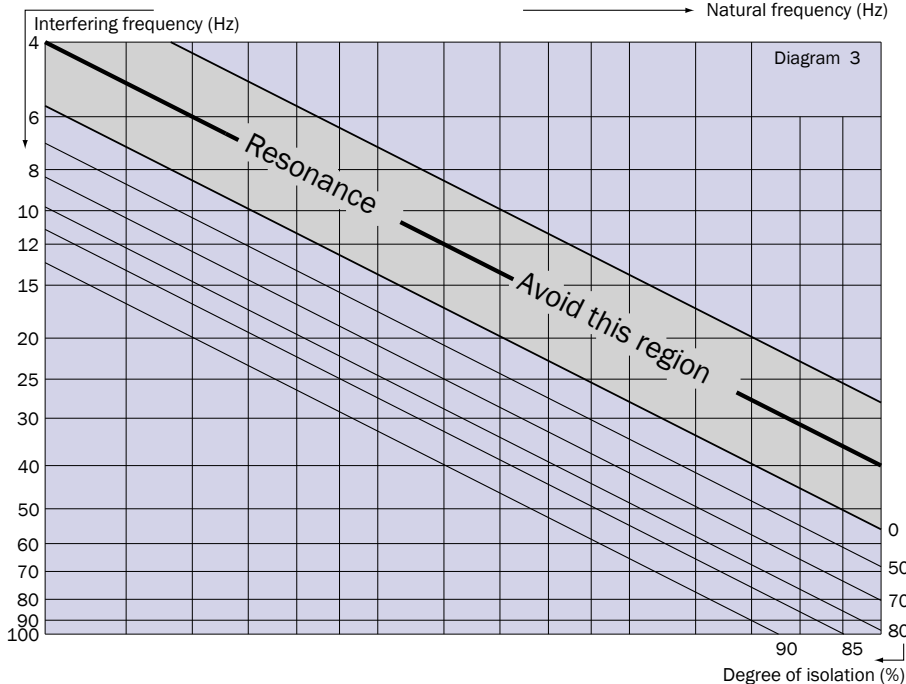
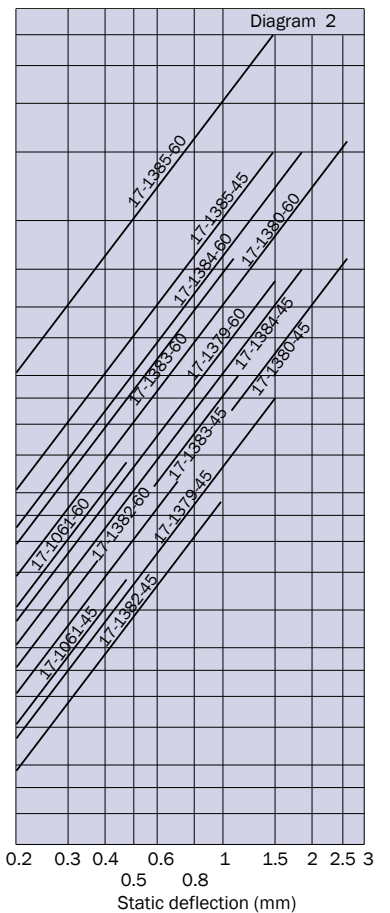
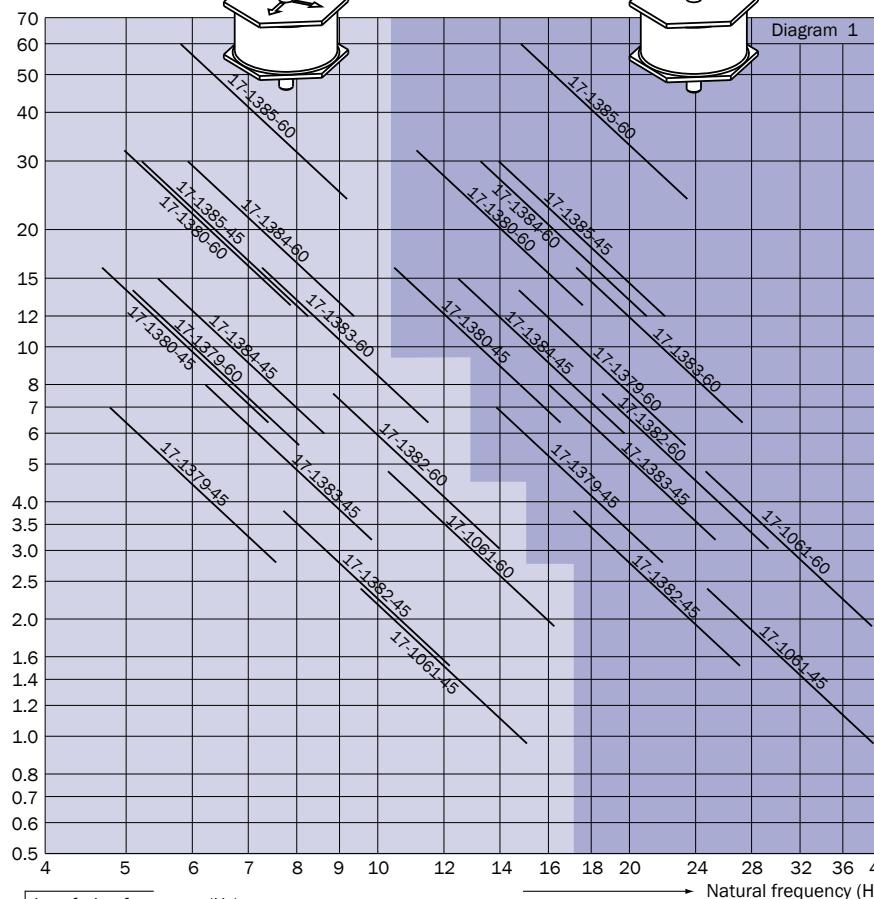

To select correct mounting, following data are needed:
 1) Load per mounting (kg)
 2) Interfering frequency (Hz) (Hz = rpm / 60)
 Select correct load line in diagram 1 and correct interference line in diagram 3. The load line intersects with required type of mounting.
 Connect this intersection point vertically down to the interference line in diagram 3. Here, on the sloping curve, the isolation degree is indicated.
 For static deflection, see diagram 2.

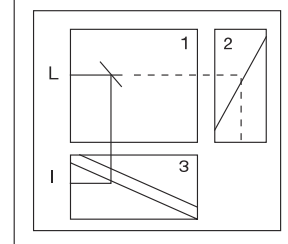

Two Bolt Instrumountings™

Note: The natural frequencies and degrees of isolation are based on dynamic characteristics of the mountings.

Load per mounting (kg)

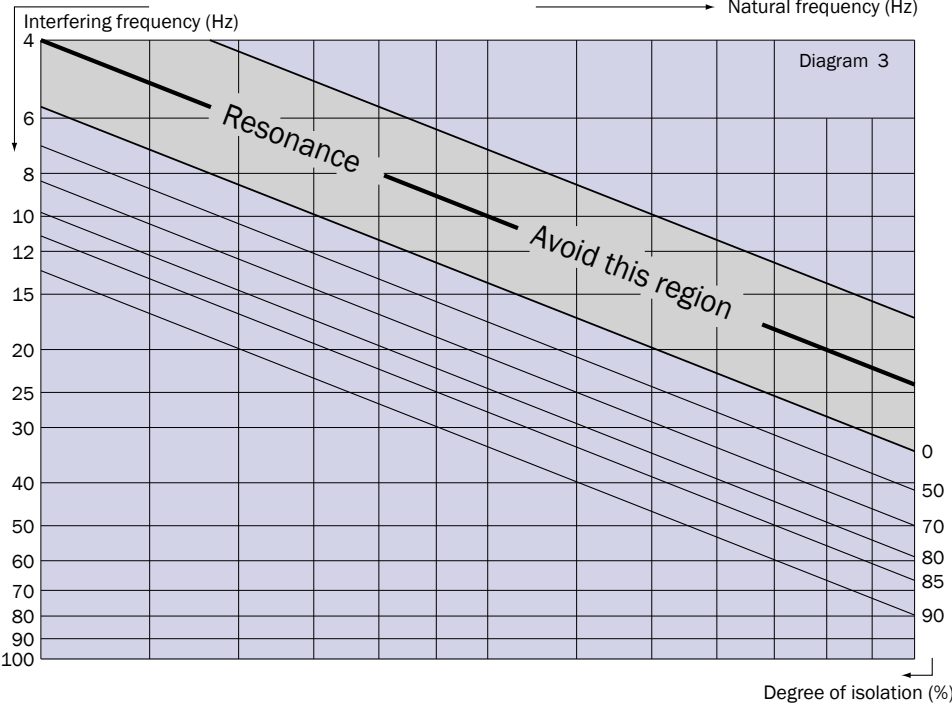
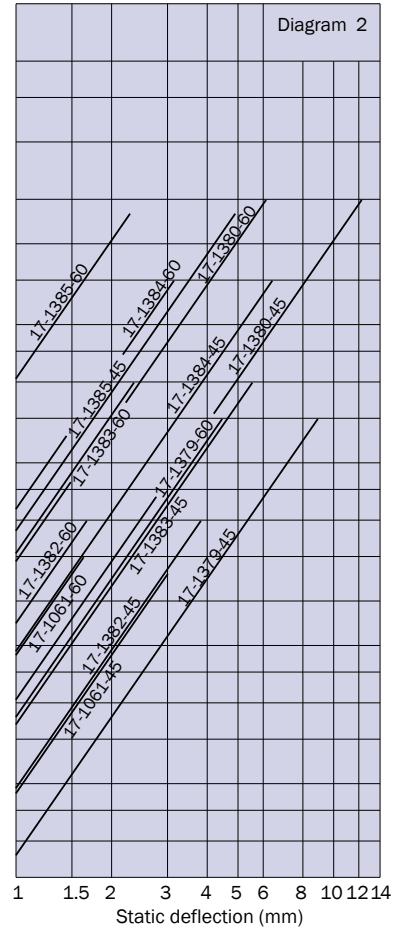
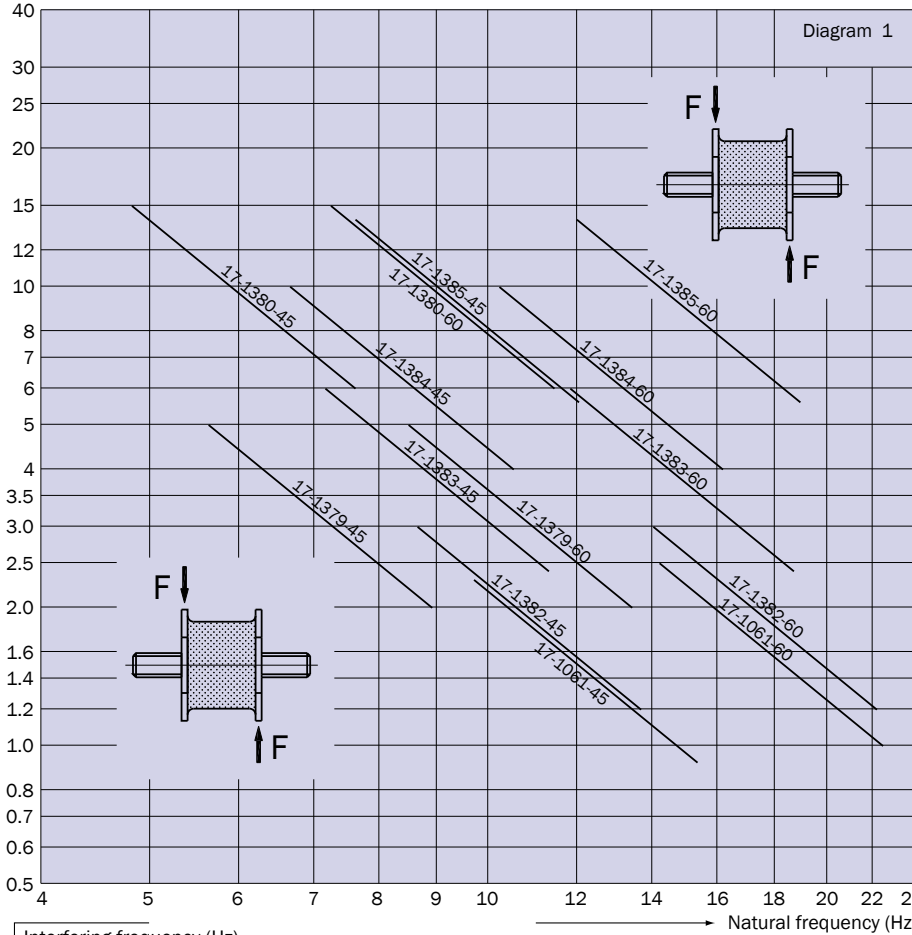

To select correct mounting, following data are needed:

- 1) Load per mounting (kg)
- 2) Interfering frequency (Hz) (Hz = rpm / 60)

Select correct load line in diagram 1 and correct interference line in diagram 3. The load line intersects with required type of mounting. Connect this intersection point vertically down to the interference line in diagram 3. Here, on the sloping curve, the isolation degree is indicated. For static deflection, see diagram 2.

