

1015. The marine engine.

195-440 kW (261 - 590 BHP) at 1500-2100 rpm



These are the characteristics of the 1015:

- Modern water-cooled four stroke 6- and 8-cylinder V-engines.
- Water-cooled turbocharger and exhaust manifolds.
- PTOs gear driven.
- Modern injection system with mechanical governor.
- Electronical governor for gen set application.
- Charge-air-cooled by engine cooling liquid.
- Innovative DEUTZ Multi-Parallel-Cooling System.
- Compact design.



Your benefits:

- ▶ High return on investment due to high fuel economy and low oil consumption.
- ▶ Plate type sea water heat exchanger guarantees low maintenance costs.
- ▶ The innovative cooling system reduces fuel consumption and is a further example of the outstanding reliability and durability.
- ▶ Low operating noise level eliminates the need for elaborate and costly noise abatement measures.
- ▶ Designed according to maritime classification rules.
- ▶ Integrated piping works for additional operating safety.

► Standard specification

Types of cooling:	Single-circuit mixed cooling as indirect cooling (DEUTZ Multi-Parallel-Cooling system) raw water cooled version with engine mounted plate-type heat exchanger, coolant circulating pump, expansion tank, thermostat and raw water pump. As keel-cooling with coolant circulating pump and integrated thermostat. Integrated expansion tank optional
Crankcase:	Crankcase of grey cast iron with wet liners
Crankcase breather:	Closed-circuit system, vacuum controlled
Cylinder head:	Individual cylinder heads of grey cast iron of crossflow design
Valve arrangement / timing	Overhead valves in cylinder head, four valve technology, actuated via tappets, pushrods and rocker arms, driven by gears and central camshaft
Piston:	Three-ring aluminium piston with cooling channel and ring carrier for top ring groove
Piston cooling:	Oil cooled with spray nozzles
Connecting rod:	Drop-forged steel rod
Crankshaft:	Drop-forged steel crankshaft with screwed-on counterweights. V6 with 30° offset crankpins (split pin).
Turbocharging:	Two liquid-cooled turbochargers and possible intercooler mounted at flywheel end
Exhaust manifolds:	Liquid-cooled exhaust manifolds
Optional vibration damper:	Viscous-fluid damper
Lubrication system:	Forced-feed circulation lubrication with gear pumps, integrated engine oil cooler, paper type microfilter as replaceable cartridge, integrated in main oil circuit, double filter as option
Injection system:	In-line injection pump with mechanical (propulsion engine) or electronic (genset) governor
Fuel injection pipes:	High pressure fuel injection pipes double walled as option
Fuel system:	Mechanical reciprocating pump, replaceable cartridge-type for fuel filter, double filter as option
Alternator:	Three-phase alternator, 28 V, 55 or 80 A
Starting system:	24 V, 5.4 kW
Heating system:	Optional connection for heating or warm water boiler to engine cooling circuit
Options:	Hydraulic pumps, flywheels, adapter housings SAE 1, oil pans, air cleaners, elastic engine mounting feet, starters, alternators, engine monitoring system, marine gears
Classification:	By all major classification societies

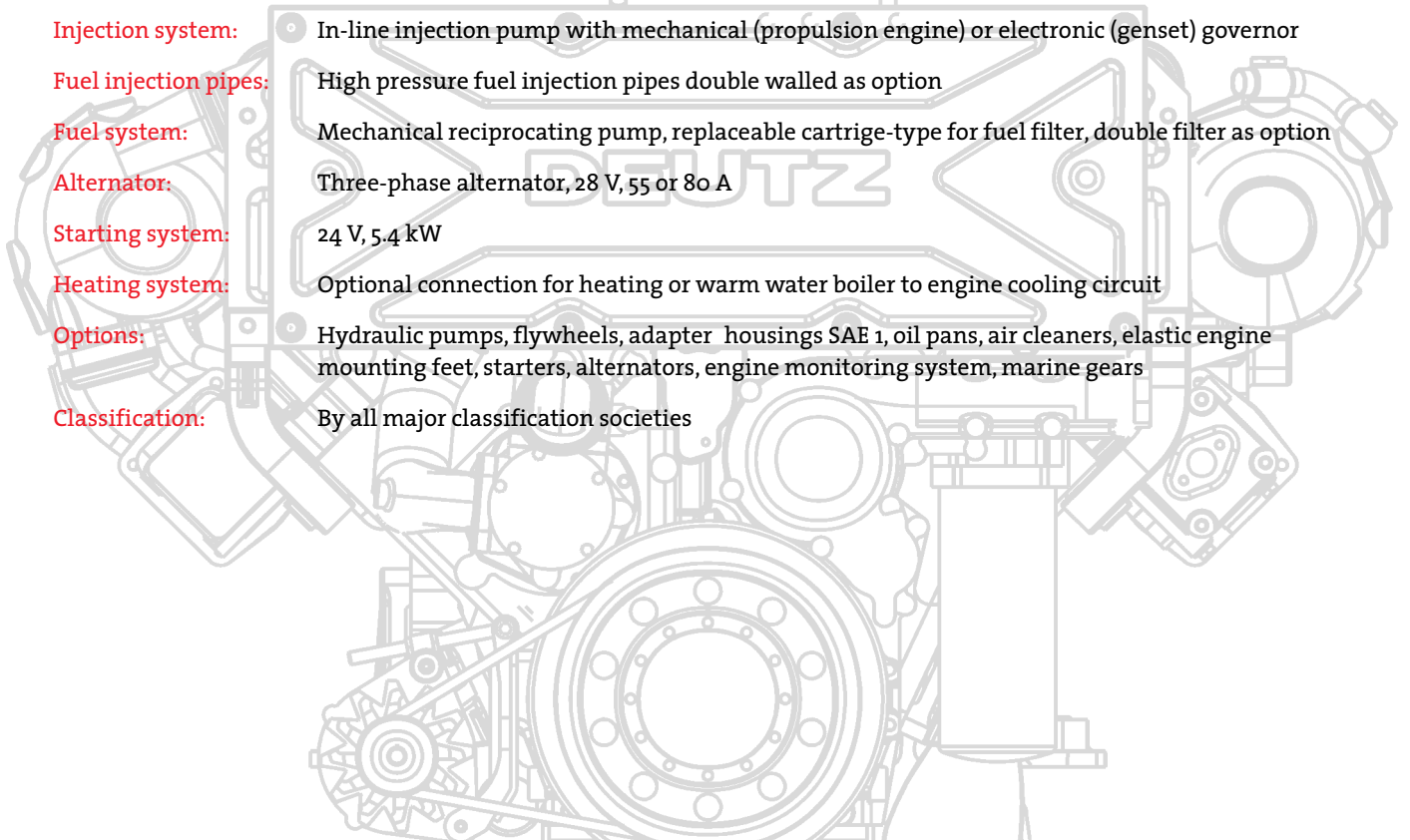

► Technical data

Engine type			BF6M1015M	BF6M1015MC	BF8M1015MC
Number of cylinders			6	6	8
Bore	mm/in		132/5.2	132/5.2	132/5.2
Stroke	mm/in		145/5.71	145/5.71	145/5.71
Displacement	l/cu.in.		11.91/727	11.91/727	15.87/968
Compression ratio			17	17	17
Power ratings for marine propulsion units					
acc. to power category A	at 1800 rpm	kW/BHP	203/272	272/365	364/488
	at 1900 rpm	kW/BHP	214/287	287/385	383/513
	at 2100 rpm	kW/BHP	214/287	287/385	383/513
acc. to power category B	at 1800 rpm	kW/BHP	228/306	313/420	418/560
	at 1900 rpm	kW/BHP	240/322	330/442	440/590
	at 2100 rpm	kW/BHP	240/322	330/442	440/590
Power ratings for on-board generating sets					
	at 1500 rpm	kW/BHP	210/282	285/382	380/509
	at 1800 rpm	kW/BHP	228/306	310/416	413/554
Weight dry incl. heat exchanger			kg/lbs	1080/2381	1180/2602
Weight as keel-cooling			kg/lbs	1020/2250	1110/2448

The values given in this data sheet are for information purposes only and not binding.
The data provided in the offer is decisive.

► Dimensions

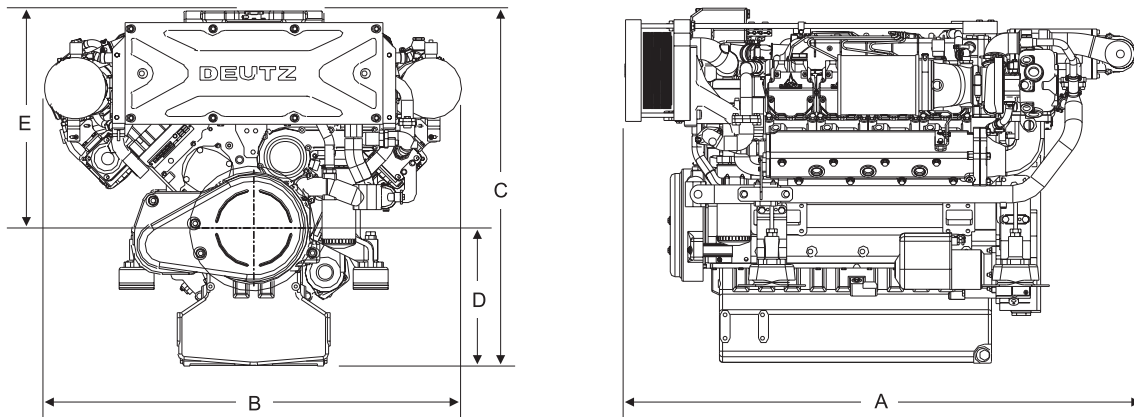

► Definitions of power ratings

Power category A: Net brake fuel stop power for continuous operation unlimited time, SCFN or ICFN to ISO 3046.

Power category B: Net brake fuel stop power for continuous operation, SCFN or ICFN to ISO 3046.

Power for on-board generating sets: Continuous power, overloadable by 10% for one hour within an operating period of 12 hours. SCXN or ICXN to ISO 3046.

Raw water cooling

Engine type		A	B	C	D	E
BF6M1015M	mm	1191	1316	1138	443	695
	in	46.9	51.8	44.8	17.4	27.4
BF6M1015MC	mm	1482	1316	1138	443	695
	in	58.3	51.8	44.8	17.4	27.4
BF8M1015MC	mm	1661	1333	1138	443	695
	in	65.4	52.5	44.8	17.4	27.4

Keel-cooling without front plate

Engine type		A	B	C	D	E
BF6M1015M	mm	1084	1316	1072	443	629
	in	42.7	51.8	42.2	17.4	24.8
BF6M1015MC	mm	1375	1316	1072	443	629
	in	54.1	51.8	42.2	17.4	24.8
BF8M1015MC	mm	1540	1333	1072	443	629
	in	60.6	52.5	42.2	17.4	24.8

Keel-cooling with front plate (integrated extension tank)

Engine type		A	B	C	D	E
BF6M1015M	mm	1228	1316	1236	443	793
	in	48.3	51.8	48.7	17.4	31.2
BF6M1015MC	mm	1520	1316	1236	443	793
	in	59.8	51.8	48.7	17.4	31.2
BF8M1015MC	mm	1683	1333	1236	443	793
	in	66.3	52.5	48.7	17.4	31.2

► Dimensions

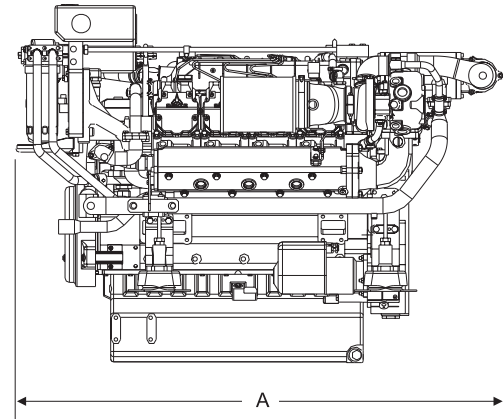
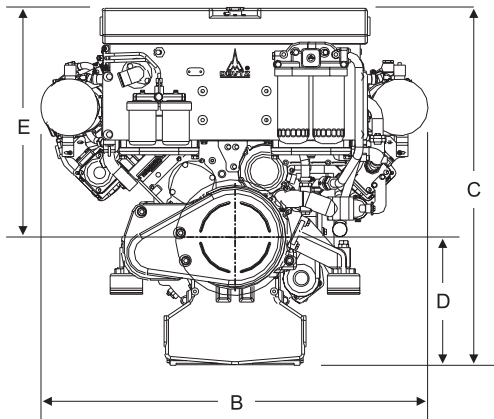
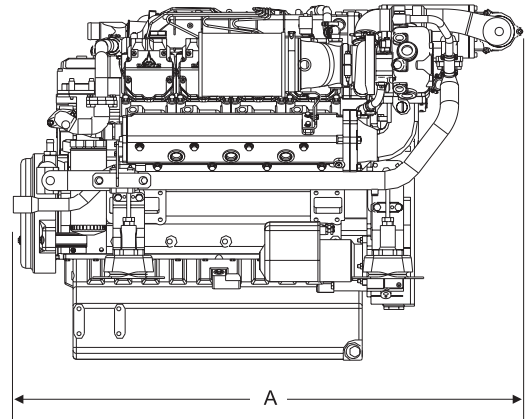
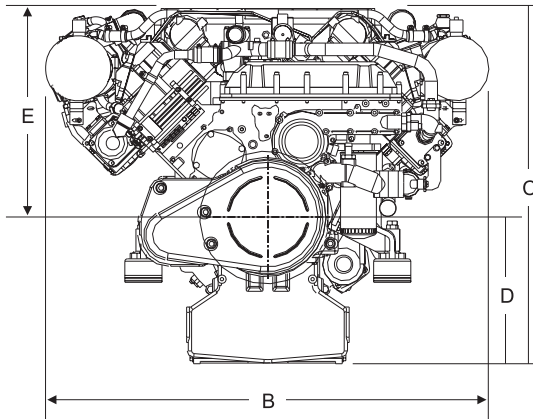

We move your world.

DEUTZ AG

DEUTZ MOTOR

Deutz-Mülheimer Str. 147-149

D-51063 Köln

Phone: +49 (0) 2 21-8 22-0

Fax: +49 (0) 2 21-8 22-22 34

Internet: www.deutz.de

eMail: marine.sales@deutz.de